

# t·r·e·s·a

TRAINING AND EDUCATION ON SMALL ARMS



## Marking and Tracing Small Arms and Light Weapons (SALW)

module MAT 07B01



t·r·e·s·a

TRAINING AND EDUCATION ON SMALL ARMS

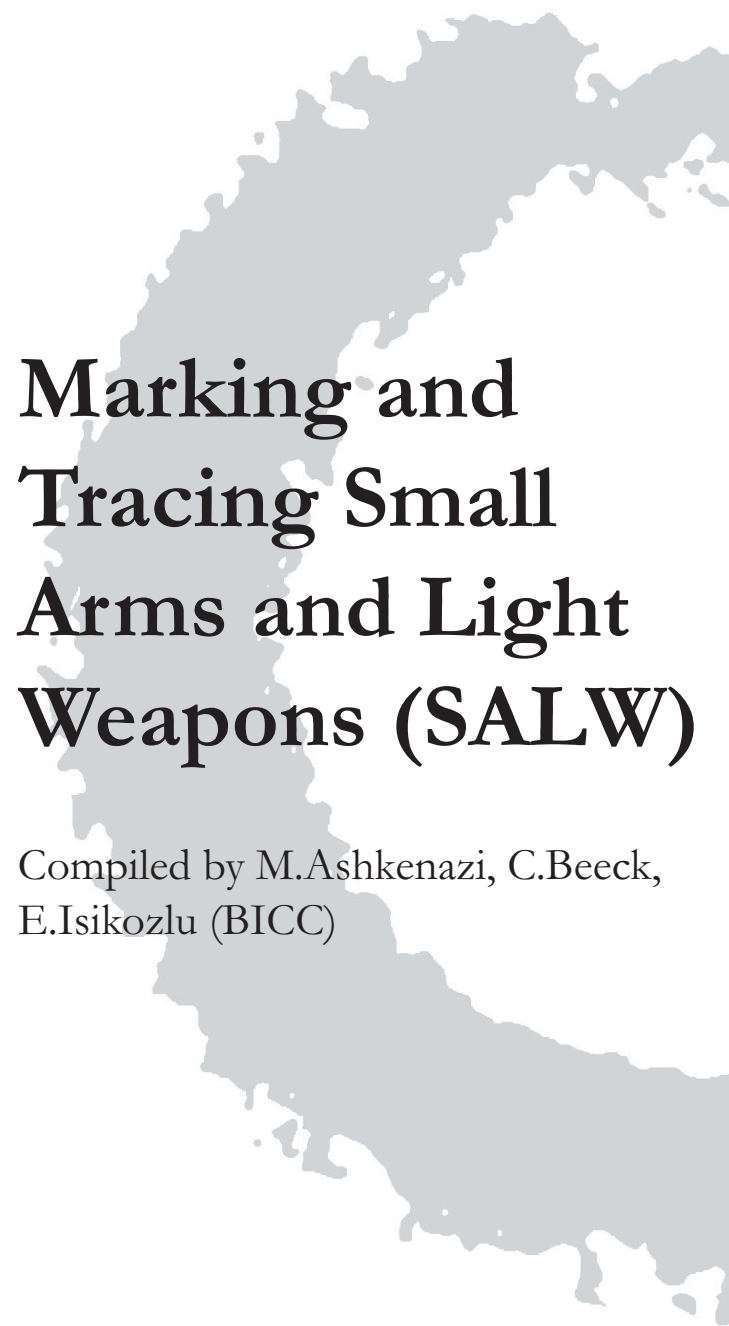

**Marking and  
Tracing Small  
Arms and Light  
Weapons (SALW)**

Compiled by M.Ashkenazi, C.Beeck,  
E.Isikozlu (BICC)

**module MAT 07B01**



Federal Foreign Office



BONN INTERNATIONAL CENTER FOR CONVERSION

B · I · C · C

This TRESA module was produced by the Bonn International Center for Conversion (BICC) under a special grant from the German Federal Foreign Office (AA).

Compiled by:	Michael Ashkenazi, Christine Beeck, Elvan Isikozlu
Executive Editor:	Christine Beeck
Concept:	TRESA BICC
Layout:	Svenja Bends

Copyright © BICC 2007

TRESA  
Internationales Konversionszentrum  
Bonn – Bonn International Center for  
Conversion (BICC) GmbH  
An der Elisabethkirche 25  
53113 Bonn  
Germany  
Phone: +49-228-91196-0  
Fax: +49-228-241215  
E-mail: [info@tresa-online.org](mailto:info@tresa-online.org)

This module was funded by a grant from the German  
Federal Foreign Ministry (Auswartiges Amt).

We are grateful for the Ministry's generous support

## FOREWORD

Germany has long recognized that the control of Small Arms and Light Weapons as well as their ammunition plays a key role in relation to human security. The adoption of the International Instrument to Enable States to Identify and Trace, in a Timely and Reliable Manner, Illicit Small Arms and Light Weapons (SALW) adopted by the United Nations General Assembly on 8 December 2005 (International Tracing Instrument) represents a major contribution towards combating the illicit accumulation and trafficking of Small Arms and Light Weapons.

Germany has actively participated in the negotiations of the International Tracing Instrument. During the negotiations the German government pleaded strongly for inclusion of ammunition as well. The German support for BICC's work on marking and tracing follows up on this commitment. This is why this TRESA module pays due attention not only to the marking and tracing of SALW, but also their ammunition.

The TRESA series is an invaluable tool for all those involved in training and education on issues related to SALW and their ammunition. This user-friendly module on *Marking and Tracing Small Arms and Light Weapons (SALW)* in the TRESA series conveys the complete picture of best practices on marking, record keeping and tracing. It confirms the need for governments, civil society and the international community to direct more attention to the challenge of marking and tracing SALW and their ammunition.

Ambassador Rüdiger Lüdeking  
Deputy Commissioner of the Federal Government for Arms Control and Disarmament  
Federal Republic of Germany

# Contents

## Trainee Preface

### Section 1 Marking SALW 1

1. Introduction	1
2. Importance and benefits of marking SALW	5
3. Towards the UN Instrument on Marking and Tracing	9
3.1 The Firearms Protocol	15
4. Marking SALW – challenges	17
5. Marking SALW – technical issues	19
5.1 What minimum information should a mark contain?	19
5.2 Marking of newly manufactured weapons	23
5.3 Marking techniques	25
5.4 Marking of already produced SALW	29

### Section 2 Record-keeping and SALW databases 1

1. Benefits of record-keeping	3
2. Challenges of record-keeping	5

### Section 3 Tracing SALW 1

1. Benefits of tracing SALW	1
2. Interpol's role	7
3. Challenges of tracing SALW	15

### Section 4 Marking and tracing of small arms ammunition

1. Marking small arms ammunition	3
1.1 Marking ammunition packaging	3
1.2 Marking ammunition bodies	11
1.3 Technical issues	11
2. Record-keeping of small arms ammunition	13
3. Tracing small arms ammunition	15
4. Recommendations	19

Section 5 The way forward: Recommendations to implement the UN M&TI at the national level	1
1. Introduction	1
2. Marking SALW	5
3. SALW Record-keeping	5
4. Tracing SALW	7
5. Addressing ammunition	9
6. Complementary measures	9
Annex I: UN Instrument on Marking and Tracing	
Annex II: Selected countries and their procedures and regulations as regards marking and tracing of SALW	
Annex III: Comparative analysis of the UN Firearms Protocol, UN PoA and UN M&TI	
Annex IV: Marking and tracing procedures of SALW in Germany	
Annex V: Marking and tracing procedures of ammunition in Germany	
Annex VI: Tracing process of a recovered weapon	
Annex VII: From producer to consumer	
References	



## Trainee Preface

This module is intended for those working to institute best practices of marking and tracing in their home countries within the framework of the UN Marking and Tracing Instrument (M&TI). The module includes all the necessary material you will need to:

- Understand the M&TI and related international documents on marking and tracing.
- Be able to influence the institutionalization of best practices regarding marking and tracing at the political, administrative, and implementation levels.

The objectives of this module are:

- To introduce the problems associated with the marking and tracing of SALW.
- To provide an overview of the various agreements and best practices on SALW marking and tracing.
- To provide an analysis of the elements of the M&TI and suggestions about how it might be implemented in practice in your country.

Copies of most key documents, as well as a case study of best practice are included as Annexes to this module. It is suggested that you keep the entire module as a reference after the end of this course.

Please use the space provided within this module on the left-hand pages to record additional information or notes from the training, as well as your ideas and answers to specific exercises and discussion questions. As we hope to make this and all other TRESA modules more targeted, relevant and useful to your area of work, we welcome any feedback and comments you might have. Please feel free to contact us at [www.tresa-online.org](http://www.tresa-online.org).

Please also note that all module abbreviations deliberately state only the first three letters (e.g. SB-D), as well as the year in which the module was written (05), whether it is the A (trainer), or B (Trainee) version. All our modules are works in progress. We therefore welcome any feedback or comments you might have. We wish you the best of luck and success in your training.

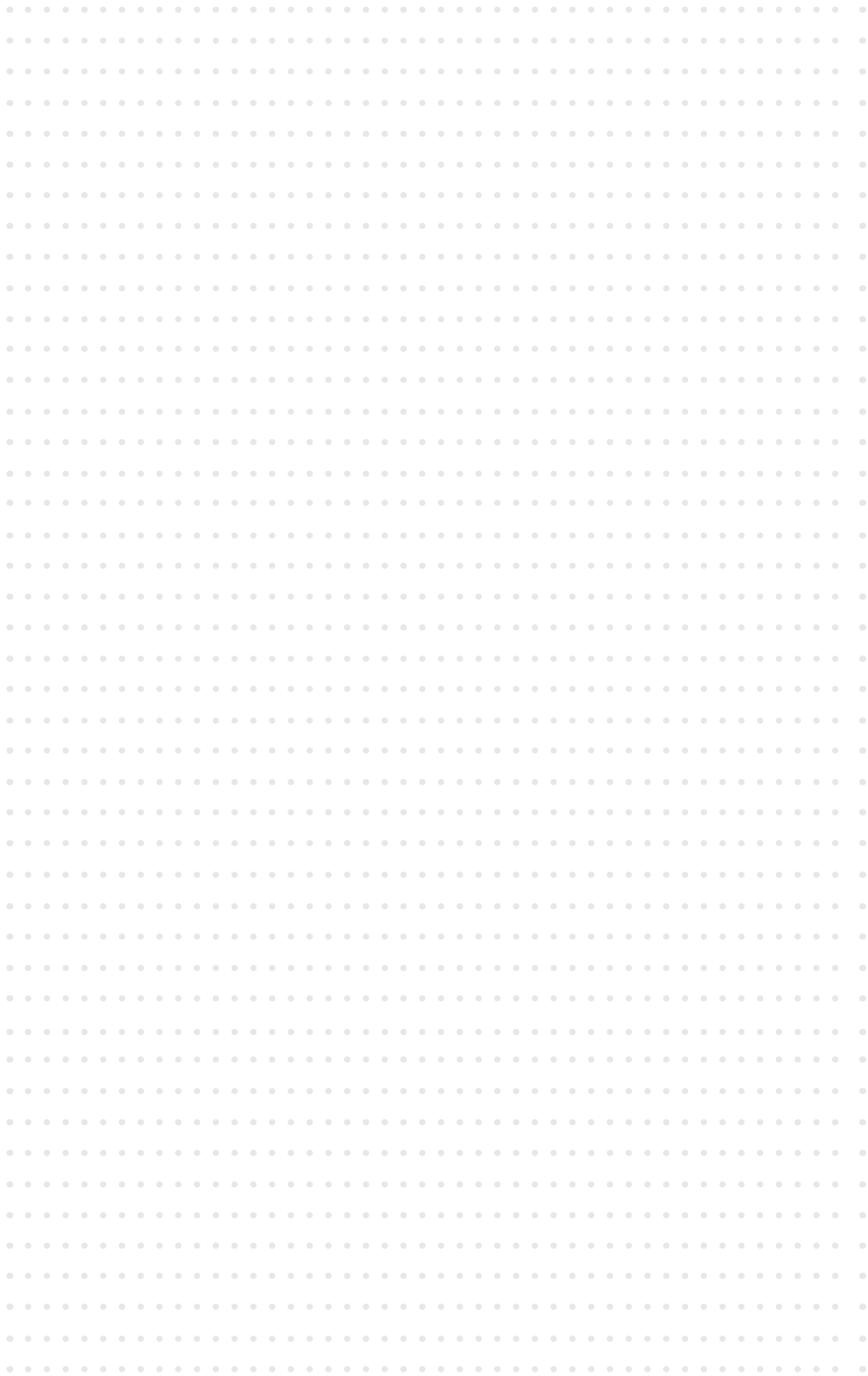

## Acknowledgements

We would like to thank Pablo Dreyfus, Research Coordinator Small Arms Control Project, Viva Rio, Brazil, James Bevan, Researcher at the Small Arms Survey (SAS) and Holger Anders, Researcher at Groupe de recherche et d'information sur la paix et la sécurité (GRIP) for their contribution and efforts in developing this training module.

Notes

---

A large grid of dots for taking notes, consisting of 30 rows and 60 columns of small, light gray dots.

# Section 1 Marking SALW

## Objectives of Section 1:

By the end of this section, each trainee should:

- Have a good overview of existing international agreements dealing with the issues of marking and tracing of SALW, particularly the UN Marking and Tracing Instrument (M&TI).
  - Have obtained a good understanding of these agreements.
- Have a good overview of the various dimensions and implications of issues surrounding marking and tracing of SALW, such as:
  - Benefits of marking SALW.
  - Different techniques of marking SALW.
  - Technical issues of marking SALW.

## 1. Introduction

### Exercise 1: Icebreaker

An assault rifle has just been recovered in a border area of your country. The weapon is presumed to be illicit due to known criminal activity and armed conflict in this area. As a government official, you are asked to find out where the rifle came from, who it belongs to, and how it got there. What type of information would you need for your investigation? Who would you approach for assistance? Brainstorm in small groups.



The following sub-sections will provide you with the legal and political frameworks, as well as the technical and practical issues that will enable you to better understand the content and implications of the UN Instrument on Marking and Tracing (M&TI). This will help build your capacity to implement the Instrument at the national, regional and international levels.

**Note:** The M&TI consolidates and reinforces key international standards in the areas of marking and record-keeping with a few exceptions. In the area of tracing cooperation and, to some extent, implementation, it goes well beyond existing norms<sup>1</sup> (see Annex I for the full document of the UN M&TI).



<sup>1</sup> Connecting the Dots. The International Tracing Document, by Glen Mc Donald, Small Arms Survey Yearbook 2006, p.95

A large grid of dots for taking notes, consisting of 30 rows and 60 columns of small, light gray dots.

*Marking and Tracing of Small Arms and Light Weapons (SALW)*

---

A large grid of dots for taking notes, consisting of 30 rows and 50 columns of small, light gray dots.



## 2. Importance and benefits of marking SALW

Despite provisions on marking and tracing in a number of regional and international agreements (see Annex II for a selection of countries and their regulations on marking and tracing of SALW) and the existence of global frameworks for tracing cooperation, such as the existing Interpol systems, tracing mechanisms are not yet fully sufficient to reliably trace weapons and ammunition from their production through their various transfers from one owner to the next. In particular, SALW recovered from armed conflicts can rarely be traced to the specific point at which they were diverted into the illicit trade.<sup>2</sup> However, to actually be able to trace a weapon, it must have a unique marking, and this marking must be adequately recorded.

**Note:** A “marking” is a unique set of numbers and/or symbols placed on a weapon to indicate its country of origin and/or country of last import as well as the weapon’s serial number (see sub-section 5. Marking SALW – technical issues for more details on what type of information a mark should ideally contain). A marking therefore provides basic information that can help identify the weapon itself, as well as its history: e.g. the weapon’s previous owners or manufacturers.



### Box 1: UN M&TI, Excerpt from Section III, Marking (paragraphs 7-10)



7. The choice of methods for marking small arms and light weapons **is a national prerogative**. States will ensure that whatever method is used, all marks required under this instrument are on an exposed surface, conspicuous without technical aids or tools, easily recognizable, readable, durable and, as far as technically possible, recoverable.

8. For the purpose of identifying and tracing illicit small arms and light weapons, States will:

**(a) Require marking at the time of manufacture, with:**

- Name of the manufacturer;
- Country of manufacture;
- Serial number / other alphanumeric or numeric code.

States will also promote marking of the year of manufacture, weapon type/model, calibre.

**(b) Require appropriate simple marking on each imported SALW** permitting identification of the:

- Country of import;
- Year of import, where possible.

States shall also require a unique marking on imported weapons that do not

<sup>2</sup> Tracking Lethal Tools. Marking and Tracing Arms and Ammunition: a central piece of the arms control puzzle, by Amnesty International, Oxfam, and IANSA (International Action Network on Small Arms), for the Control Arms Campaign, p.5, [http://www.oxfam.org.uk/what\\_we\\_do/issues/conflict\\_disasters/downloads/tracking\\_lethal\\_tools](http://www.oxfam.org.uk/what_we_do/issues/conflict_disasters/downloads/tracking_lethal_tools).

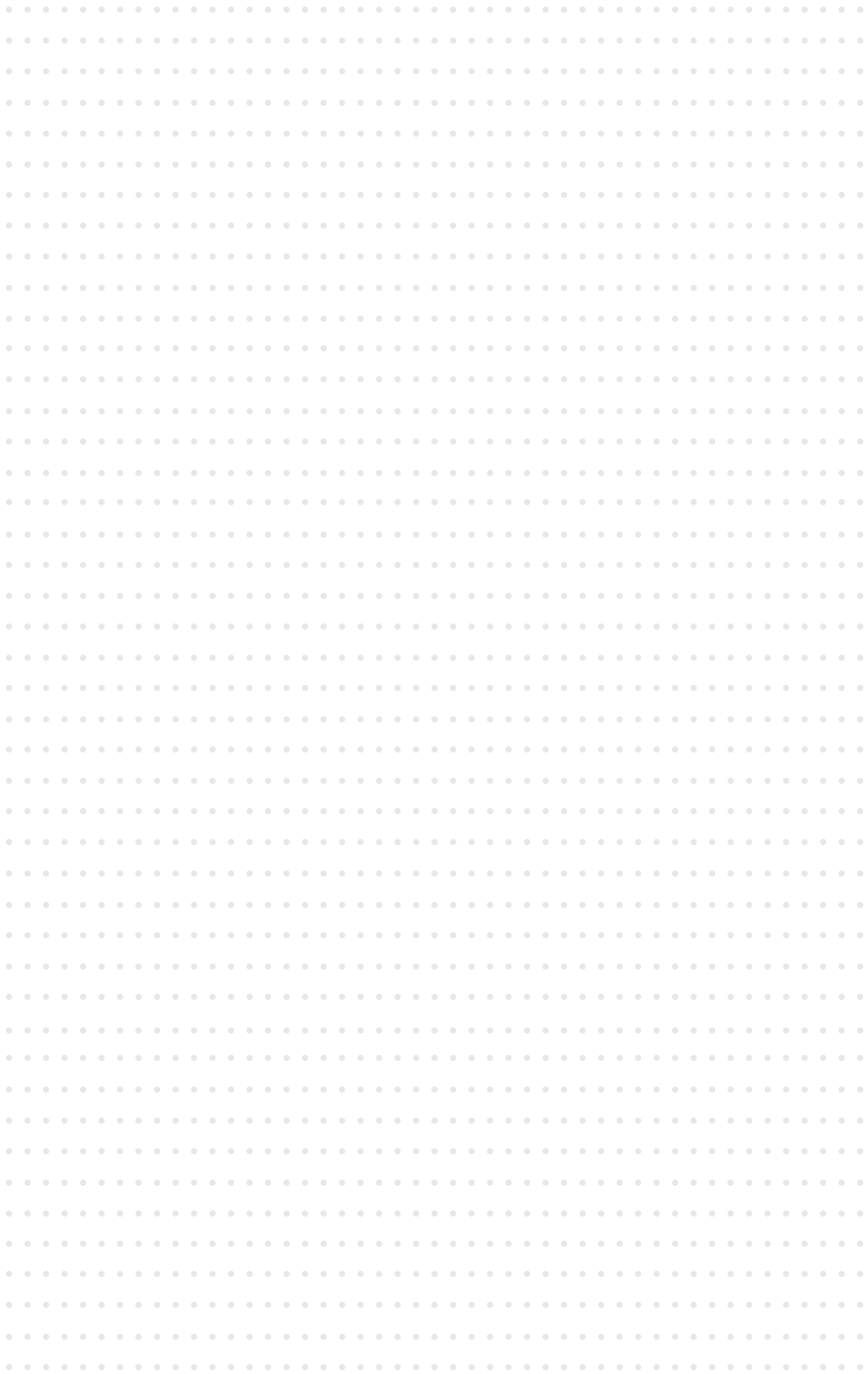

already bear markings, with the exception of temporary imports or imports of museum artefacts.

**(c)** Ensure that all weapons transferred from government stocks to civilian use are marked, identifying the country from whose stocks the transfer is made;

**(d)** Ensure that all small arms and light weapons in the possession of government armed and security forces are duly marked. Markings on these small arms and light weapons do not necessarily have to meet the requirements of subparagraph 8 (a) above;

**(e)** Encourage manufacturers of small arms and light weapons to develop measures against the removal or alteration of markings.

9. Ensure that all illicit small arms and light weapons that are found on their territory are uniquely marked and recorded, or destroyed, as soon as possible.

10. Ensure that every small arm or light weapon always receives the unique markings prescribed in subparagraph 8 (a) above...to an essential or structural component of the weapon where the component's destruction would render the weapon permanently inoperable... .

Source: International Instrument to Enable States to Identify and Trace, in a Timely and Reliable Manner, Illicit Small Arms and Light Weapons (UN M&TI), pp.3-4, [http://www.un.org/events/smallarms2006/pdf/international\\_instrument.pdf](http://www.un.org/events/smallarms2006/pdf/international_instrument.pdf)

The **marking of SALW can help identify the weapon's country of origin, manufacturer and/or last country of import, and can hence be viewed as a prerequisite to becoming engaged in the control of illicit SALW.** As SALW often get "lost" from insecure stockpiles, or are legally sold and then diverted into illicit routes, **marking, record-keeping and tracing of SALW can be basic preventive measures implemented at the national level to prevent illicit trafficking of SALW at the national, regional and international levels.**

**Exercise 2: Why is marking important?**

In small groups of 2-3 people, discuss why the marking of SALW is important and record your answers.



**Note:** Marking of weapons on import, as recommended in the M&TI (Section III, 8b; see Box 1 above) is critical to tracing a weapon down its transfer chain. This is particularly true if the weapon is old and has been in circulation for a long time, which is the case with many conflict weapons. States should take all necessary measures to ensure that all weapons are marked on import.



A large grid of dots for taking notes, consisting of 30 rows and 50 columns of small, light gray dots.



### 3. Towards the UN Instrument on Marking and Tracing

As many legally manufactured, transferred and/or stored SALW enter illicit circulation, and by doing so become untraceable, **marking and tracing of SALW are crucial elements in:**

- **Preventing arms from falling into “the wrong hands”, for example through the sale or theft of military or police surplus SALW stocks; and from being used in criminal activities, armed conflicts and/or human rights abuses;**
- **Effectively tackling the illicit trade in SALW.**

A large grid of dots for taking notes, consisting of 30 rows and 50 columns of small, light gray dots.

Causal chain chart: benefits of marking

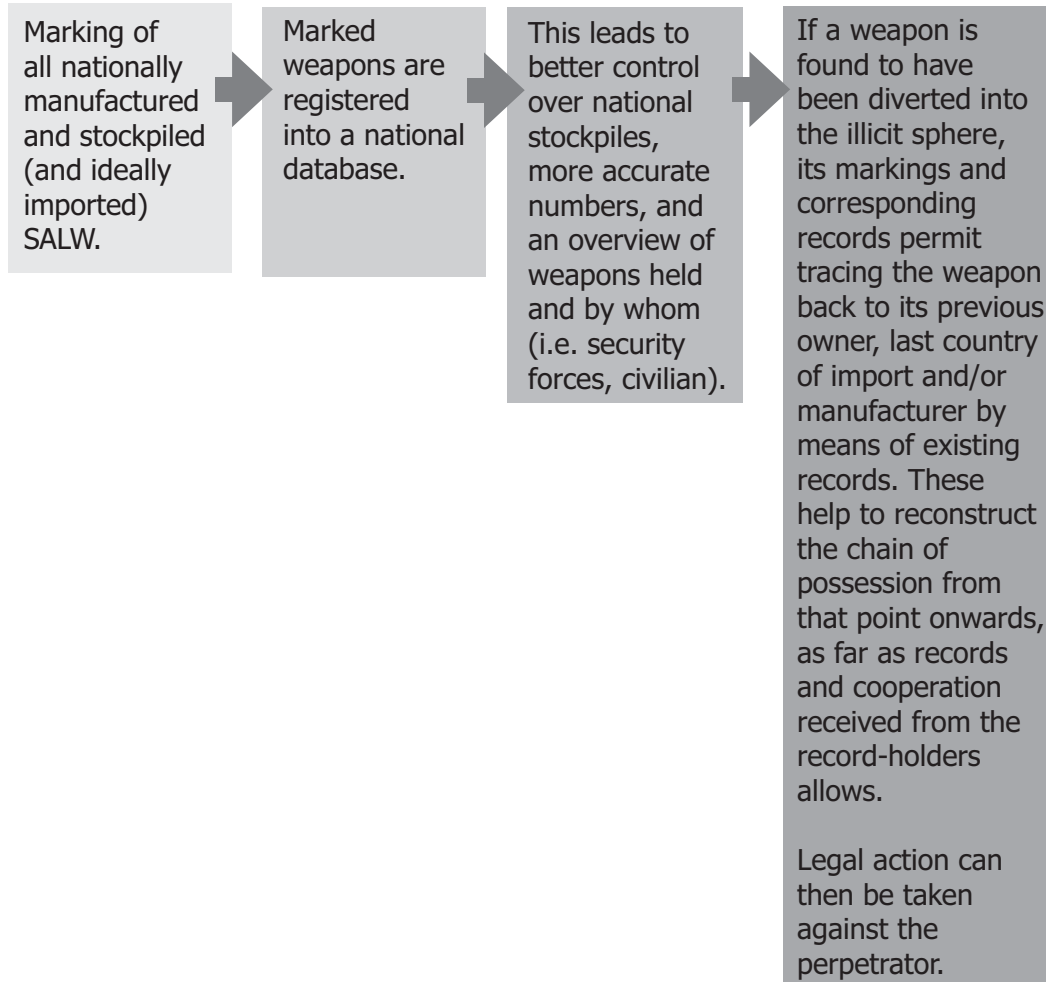

**Note:** In December 2001, the UN General Assembly established a Group of Governmental Experts on Tracing Illicit SALW (GGE), as a direct follow-up of the UN Programme of Action to Prevent, Combat and Eradicate the Illicit Trade in Small Arms and Light Weapons in all its Aspects (UN PoA, 2001). Pursuant to the GGE's report of July 2003, an Open-Ended Working Group Tracing Illicit SALW (OEWG) was set up in December the same year. Building upon the work of the GGE, the OEWG compromised on the draft of today's M&TI after heated discussions in June 2005. The Instrument was finally adopted by the UN General Assembly in December 2005. For details on the work of the GGE and the OEWG, see *Connecting the Dots. The International Tracing Document*, by Glen Mc Donald, *Small Arms Survey Yearbook 2006* (Chapter 4).



A large grid of dots for taking notes, consisting of 30 rows and 40 columns of small, light gray dots.



## Advantages of the UN M&TI

- The instrument **applies to all UN member states and is hence universal in scope**. All UN member states have committed themselves to meeting the set out requirements.
- While the UN M&TI's obligations relating to marking and record-keeping are technically similar to those of the UN Firearms Protocol, it **helps strengthen existing minimum standards on record-keeping by substantially extending the minimum period over which records must be kept**.
- Its **substantial elaboration of obligations and procedures for reliable and timely cooperation in tracing illicit SALW**.  
**Note:** The instrument encourages technical and financial assistance and cooperation on implementation, though it does not establish specific mechanisms or procedures to promote and facilitate such cooperation.
- The UN M&TI aims to **tackle illicit weapons in both crime and conflict settings**.
- It **provides for cooperation with both the UN and Interpol**, including exchange of key information concerning markings used to indicate the country of manufacture and country of import<sup>3</sup>.
- The M&TI looks to the future, **committing states to regular reports and meetings on the instrument's implementation**. Its reporting and review mechanisms are explicitly integrated with those of the PoA itself. Hence, states will review the **implementation and future development of this instrument within the framework of PoA Review Conferences**. These reviews could not only potentially lead to the instrument's transformation from a political to a legally binding agreement, but could also result in a further development of the instrument's content<sup>4</sup>.
- **The instrument extends the length of time that states are required to keep weapons records**, thereby extending the UN Firearms Protocol's 10-year standard.



Source: Adapted from "Reviewing Action on Small Arms 2006. Assessing the first five years of the UN programme of Action. Biting the Bullet".

## Disadvantages of the UN M&TI

- The new International Tracing Instrument is **politically but not legally binding**.
- While the instrument's scope is generally wider than that of the UN Firearms Protocol, it **does not cover SALW ammunition**, but only weapons, their parts and components.

<sup>3</sup> Too close for comfort: an analysis of the UN tracing negotiations, Peter Batchelor and Glenn McDonald, p.45, In: Disarmament Forum, "Taking Action on Small Arms, 2006 no. 1, <http://www.unidir.ch/pdf/articles/pdf-art2429.pdf>

<sup>4</sup> Cf. above

A large grid of dots for taking notes, consisting of 30 rows and 50 columns of small, light gray dots.



**Note:** While the majority of states wanted ammunition to be included in the instrument a number of states viewed that ammunition was seen to raise issues that differ from those relating to SALW. The USA and a few other countries hence insisted that ammunition was excluded. The Open-Ended Working Group (OEWG) that negotiated the tracing instrument recommended, however, that the issue of ammunition be addressed in a comprehensive manner as part of a separate UN process<sup>5</sup>.

- Its mechanisms for promoting implementation of the instrument at the national and international level, and further development of the instrument are not very specific.
- Import marking is strongly recommended but is not mandatory, which is the document's key weakness. The older the weapon, the more likely it is that the record-keeping chain will be broken. An import mark would considerably increase the chance of a successful trace<sup>6</sup>.
- Though the UN M&TI aims to **tackle illicit weapons in both crime and conflict settings**, the UN M&TIs' framework for conflict tracing is underdeveloped as it does not provide specifics.

Source: Adapted from "Reviewing Action on Small Arms 2006. Assessing the first five years of the UN programme of Action. Biting the Bullet".

### 3.1 The Firearms Protocol

Besides the UN M&TI, several other already existing international and regional agreements include issues related to the marking and tracing of SALW. One of them is the UN Firearms Protocol, which entered into force in July 2005. It complements the UN PoA and includes several legally-binding commitments relating to the marking, record-keeping and tracing of firearms. The protocol:

- Includes firm and specific obligations on **marking**, including the requirement for unique marking at the point of manufacture of each firearm with:
  - The manufacturer's name.
  - The country or place of manufacture.
  - The serial number or alternative user-friendly and unique marking system.
  - Simple additional marks at the point of importation.
- Commits states to ensure the maintenance of records for at least 10 years to enable the tracing of firearms and, where possible, their parts, components and ammunition.

<sup>5</sup> The International Tracing Instrument: Challenges and Opportunities. PrepCom side event, 2006 Small Arms Review Conference, by Glen McDonald, Small Arms Survey, UN New York, 13 January 2006, p.1

<sup>6</sup> Adapted from: The International Tracing Instrument: Challenges and Opportunities. PrepCom side event, 2006 Small Arms Review Conference, by Glen McDonald, Small Arms Survey, UN New York, 13 January 2006, p.2

A large grid of dots for taking notes, consisting of 30 rows and 50 columns of small, light gray dots.

- Has strong overall commitments on **cooperation on tracing**, including:
  - An obligation to provide prompt responses to requests for assistance in tracing.
  - Cooperation on technical training and assistance.

**A weakness of the Firearms Protocol is that it** does not specify further the obligations and procedures for cooperation in tracing and **only focuses on weapons related to crime** (for a comparative analysis of the UN Firearms Protocol, UN PoA and UN M&TI see Annex III).

**Note:** In addition to the UN Firearms Protocol, other existing international and regional agreements contain provisions for substantial politically or legally binding commitments on marking, record-keeping and tracing of SALW. These are however not discussed within the framework of this training module. For more details and a comparison, see *Connecting the Dots. The International Tracing Document*, by Glen Mc Donald, *Small Arms Survey Yearbook 2006* (Chapter 4).



## 4. Marking SALW – challenges

Most states apply their own national laws or regulations with respect to the marking of SALW and record-keeping associated with their national manufacture and trade. As a result, **little**, if any **inter-state harmonization as regards marking, record-keeping and tracing exists** to date in most parts of the world. The M&TI attempts to address this lack of harmonization by establishing common minimum standards for marking and record keeping of nationally manufactured or imported SALW.

Additionally, marks on weapons may:

- Be missing.
  - Be misleading.
  - Have largely been removed or completely removed to conceal origin or ownership.
  - Be false to deliberately disguise the manufacturer and/or country of manufacture.
  - Be incomplete.
- During the lifespan of a weapon, old or malfunctioning components of a weapon may often be replaced by new components or spare parts from other weapons. Thus an individual illicit weapon may be pieced together with components coming from a variety of sources<sup>7</sup>.
  - Marks with information on the manufacturer and/or country of manufacture are of limited use for tracing purposes in the absence of a further 'unique identifier' or serial number of that particular weapon.

<sup>7</sup> TRACING ILLICIT SMALL ARMS. Opportunities for the first substantive session of the Open-Ended Working Group on Tracing Illicit Small Arms and Light Weapons, IANSA, DRAFT – MAY 2004, P.4, [HTTP://WWW.IANSA.ORG/ISSUES/DOCUMENTS/IANSA\\_POSITION\\_PAPER\\_ON\\_TRACING.DOC](http://www.iansa.org/ISSUES/DOCUMENTS/IANSA_POSITION_PAPER_ON_TRACING.DOC)

A large grid of dots for taking notes, consisting of 30 rows and 50 columns of small, light gray dots.

- Some national armed forces specify that weapons manufactured for them be without marks so they can apply their own markings later. Such unmarked weapons can find their way into illicit proliferation through diversions during delivery and theft from stockpiles. Unmarked or inadequately marked arms may intentionally be stocked for transfer to political allies that a government wishes not to be seen openly supporting<sup>8</sup>.

Further **elements that are often difficult or even lacking are cooperation, coordination, and communication between governments on issues surrounding marking and tracing.** One reason for this absence of cooperation may be due to technical issues and difficulties of marking.

### Box 2: Missing elements

In addition to the above, standards on how to read the marking on a weapon, e.g. what the abbreviations and/or symbols stand for (year, name of manufacturer, country of origin), is not yet available. It is hence very important and recommended that:

- Security personnel who are dealing with these issues be well trained;
- Cooperation be encouraged between:
  - national agencies holding SALW, as well as
  - regional and international law and security enforcement personnel.

## 5. Marking SALW – technical issues

### 5.1 What minimum information should a mark contain?

To understand the challenges of marking SALW and small arms ammunition, it is important to first understand how they are marked. To date, **different states use different technologies and formats to mark their weapons, and the information provided in the marking varies.** While the M&TI leaves it up to the individual State to **determine** the method of marking (e.g. stamping, engraving, etc.), the M&TI specifies the **characteristics** the marking should contain (see UN M&TI, paragraph 7, in Box 1 above).

Have a closer look at Box 3 below to see what a marking can look like and the type of information it can contain. For more information on marking of small arms ammunition and ammunition lots, see Section 4 and Annex V.

<sup>8</sup> Tracking Lethal Tools. Marking and Tracing Arms and Ammunition: a central piece of the arms control puzzle, by Amnesty International, Oxfam, and IANSA (International Action Network on Small Arms), for the Control Arms Campaign, p.9, [http://www.oxfam.org.uk/what\\_we\\_do/issues/conflict\\_disasters/downloads/tracking\\_lethal\\_tools.pdf](http://www.oxfam.org.uk/what_we_do/issues/conflict_disasters/downloads/tracking_lethal_tools.pdf)

A large grid of dots for taking notes, consisting of 30 rows and 60 columns of small, light gray dots.



### Box 3: Location and sample of German markings

Sample of German proof firing mark:



#### 1.1.4 Kennzeichnungsstellen

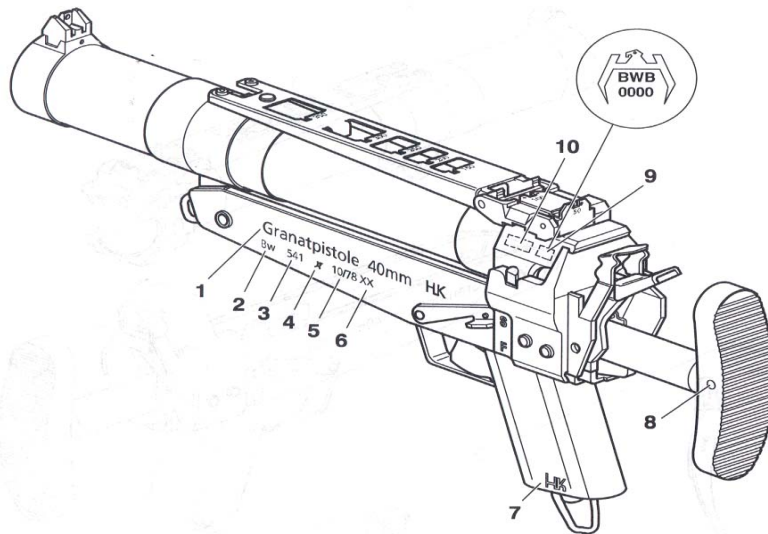

**Bild 4** Kennzeichnungsstellen

- |  |                                      |
|--|--------------------------------------|
| 1 Gerätebezeichnung  | 6 Beschußstempel/Güteprüfstempel     |
| 2 Eigentumskennzeichen   | 7 Herstellerkurzzeichen              |
| 3 Fertigungsnummer   | 8 Kennzeichen für geänderte Fangrast |
| 4 Kennzeichnung mit Stern des SIZ  | 9 Beschußstempel                     |
| 5 Monat und Jahr der Herstellung<br>(rechte Seite: Monat und Jahr der Hauptinstand-<br>setzung, Kennzeichen des Inst-Zentrums) | 10 dreistellige Endnummer der Waffe  |

- 1) Type of weapon/model
- 2) Property stamp/weapons' owner [in this case: BW (Bundeswehr, the Federal Armed Forces)]
- 3) Manufacturing number
- 4) Asterisk for system maintenance center
- 5) Month/year of manufacture (right-hand side: month/year of major repair, monogram of maintenance center)
- 6) Proof firing stamp/inspection stamp
- 7) Manufacturer's stamp [in this case: H&K (Heckler & Koch)]
- 8) Mark for modified catch
- 9) Proof firing stamp
- 10) Last three digits of item no

Source: National Report on the Implementation of the United Nations Programme of Action to Prevent, Combat and Eradicate the Illicit Trade in Small Arms and Light Weapons in All Its Aspects, Federal Republic of Germany, Berlin, April 15, 2007, p.52

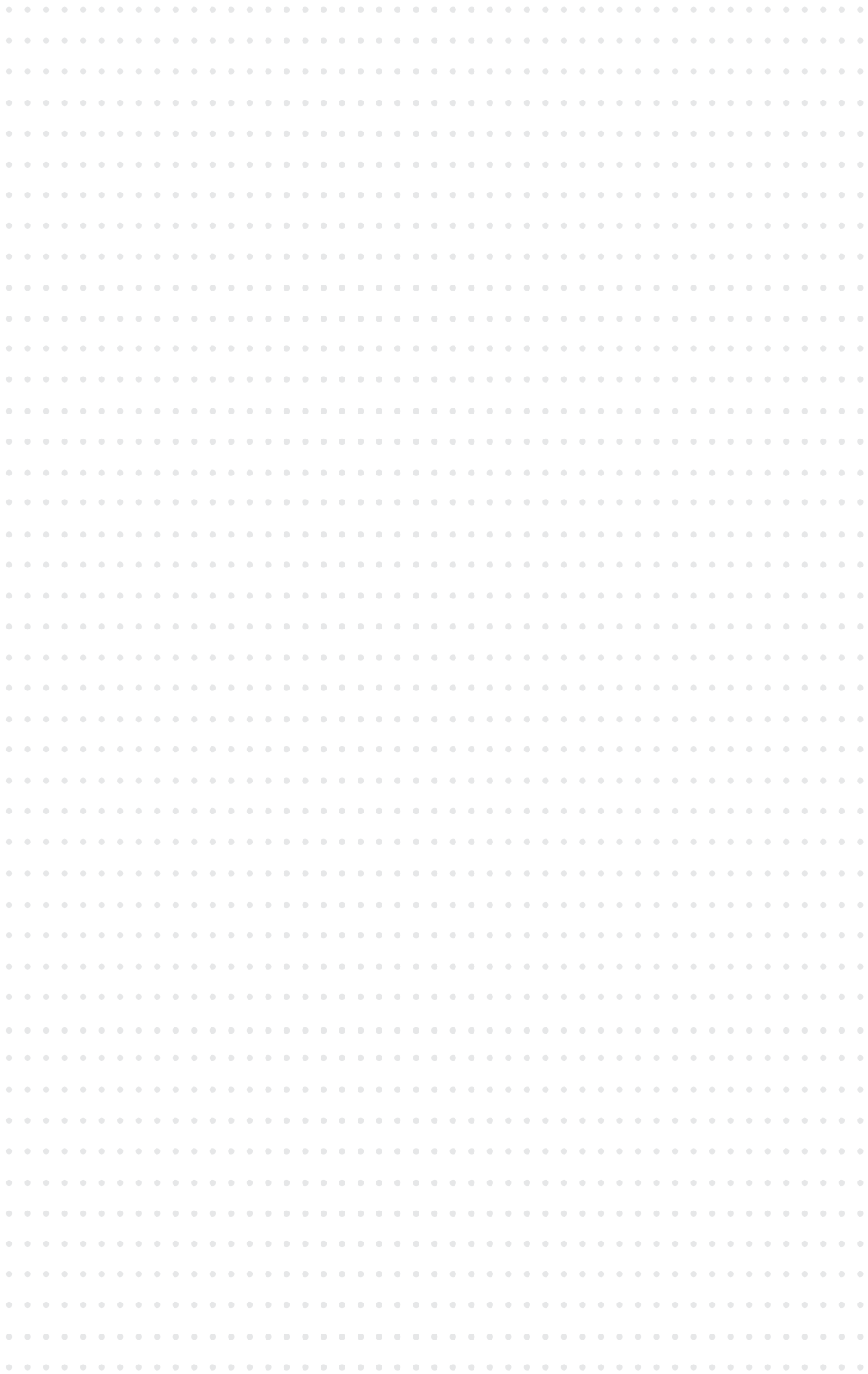



Source: IMI

Note: Markings are clearly visible on the frame, above the hand grip.

**Markings are usually found on the bolt/bolt carrier, the receiver/frame and the barrel of each weapon (see illustration above of weapon parts).**

## 5.2 Marking of newly manufactured weapons

Some governments, the German government among others, request that all manufactured weapons be marked at the point of production with a unique serial number, manufacturer's mark and country code (see Annex IV on marking and tracing procedures of SALW in Germany). This information is placed on the weapon's essential or structural components, is clearly visible and of a permanent nature. At times there is a specification that marks should be applied to places that are difficult to reach and/or the removal of which would make the firearm inoperable. Following best practice, additional marks should furthermore identify the year of manufacture, and the year and country of import, in line with the strong recommendations made by the UN M&TI (See Box 1 above).<sup>9</sup>

**Note:** Other 'Best Practice Guides' are complementary to the measures and recommendations of the UN M&TI. These include guides being developed by GRIP and the OSCE Best Practice Guide Series on issues related to marking and tracing of SALW.



<sup>9</sup> Tracking Lethal Tools. Marking and Tracing Arms and Ammunition: a central piece of the arms control puzzle, by Amnesty International, Oxfam, and IANSA (International Action Network on Small Arms), for the Control Arms Campaign, p.9, [http://www.oxfam.org.uk/what\\_we\\_do/issues/conflict\\_disasters/downloads/tracking\\_lethal\\_tools.pdf](http://www.oxfam.org.uk/what_we_do/issues/conflict_disasters/downloads/tracking_lethal_tools.pdf)

A large grid of dots for taking notes, consisting of 30 rows and 50 columns of small, light gray dots.

Exercise 3:

Take a close look at the photo provided by your trainer. Look at its marking and try to identify the model of the weapon, its manufacturer, its serial number and the year it was produced in. Are these markings in line with the UN M&TI?



Trainee Note (Exercise 3)

Note that the order and format of the markings are normally dictated by the national manufacturer. The MT&I does not recommend a universal format (i.e. order of information) for SALW markings, as these must first serve the needs of the national manufacturer and relevant authorities. The trick to understanding the markings is to ensure they are properly recorded.

### 5.3 Marking techniques

A large variety of marking techniques can be used, but markings should be easily identifiable, difficult to alter or remove and, if altered or removed, easily recoverable through technical means. A comparison of the various techniques available requires an analysis based on a number of criteria, such as resistance to erasing (through wear and tear or as the result of deliberate counterfeiting), information accessibility, information storage capability, maintenance, cost, etc. Moreover, the choice of a technique should take into account the material of which the weapon is made (steel, alloys or resins), and the type of weapon to be marked.

#### Box 4: Traditional processes of marking SALW—OSCE Best Practice

**Note:** With a number of issues relating to marking and tracing and their implementation, the OSCE Best Practice Guide goes into more detail than the UN M&TI. We therefore recommend you to consider this guide as a complementary document to the UN M&TI.



- i) **Stamping:** Sufficient force is applied to a matrix bearing the information. Under the impact of the force applied, the matrix produces a mark by making an indent in the metal. The depth of the mark depends on the matrix used, the metal to be marked and the degree of force applied.
- ii) **Casting.**
- iii) **Engraving:** Removing metal with engraving tools such as hand-held chisels, routers, acid or laser beams.
- iv) **Hot marking:** Used particularly for resin parts.
- v) **Riveting or soldering a plate:** Notably for certain thin metal firearms on which other processes would be hard to use.

For barrelled weapons, stamping is generally thought to provide the best guarantee in terms of resistance to erasing, accessibility of information and cost. Contrary to other

A large grid of dots for taking notes, consisting of 30 rows and 50 columns of small, light gray dots.

processes, stamping actually substantially alters the molecular structure of the metal, which ensures that the data will remain despite attempts to erase it.

Very different techniques may be preferred for some light weapons (mortars, portable rocket launchers, grenade launchers, etc). If possible, a weapon should be marked in such a way that removing or altering markings will render the weapon permanently inoperable. Research is under way to perfect sophisticated marking systems involving new technologies that still require substantial investment. These technologies include:

- Chemical tracers.
- Radio frequency identification (RFID) systems.
- Electronic chips inserted into weapon structure.
- Adding a traceable metallic element to the steel or aluminium alloy.
- Including coloured particles in the steel or plastic parts.
- Mechanical deformation<sup>10</sup>.

Other provisions for reliable marking

To provide maximum guarantees, marking must be included in the manufacturing process and should be certified by internationally recognized quality standards<sup>11</sup>. The administrative bodies and economic agencies responsible for marking at each stage of a marked weapon's life should be explicitly designated in national legislation and regulations, as should the marking system they should apply. In any agreement on the transfer of a licence or relocation of production activity, the commercial and industrial clauses governing the operation should provide for the implementation of specific marking provisions, as defined both by this guide and a suitable industrial and commercial monitoring facility.

Source: Best Practice Guide on Marking, Record-keeping and Traceability of Small Arms and Light Weapons, pp.6-7, [http://www.osce.org/publications/fsc/2003/12/13550\\_31\\_en.pdf](http://www.osce.org/publications/fsc/2003/12/13550_31_en.pdf)



### Box 5: Marking of small arms by German weapons manufacturer Heckler & Koch

The means by which Heckler & Koch weapons are marked depends on the carrier material, that is, the material the weapon is made of:

- While previously the metal was engraved mechanically, markings today are nearly always laser-engraved.
- Plastic is being stamped using injection molding machines during the production process.

<sup>10</sup> This last method consists of making minute holes to mark a code on the weapon's frame. Once the production process is complete, the weapon is polished to render the marking invisible. To recover the marking, a suitable chemical solution is used or the weapon is x-rayed.

<sup>11</sup> See OSCE Best Practice Guide on National Controls over Manufacture of Small Arms and Light Weapons, downloadable from: [http://www.osce.org/publications/fsc/2003/12/13550\\_30\\_en.pdf](http://www.osce.org/publications/fsc/2003/12/13550_30_en.pdf)





Where are H&K markings situated on a weapon?

The markings of H&K weapons can be found on the main part of the weapon, such as the barrel, barrel catch and, in some weapons, the handle. Weapons with exchangeable parts contain markings on all parts that can be exchanged, e.g. the barrel, slide or bolt.

**Note:** The position of the markings on the weapon also depends on:

- The material the weapon is made out of.
- Its design.
- Whether it is a long gun (a firearm with an extended barrel) or a handgun.

**What information does the marking contain?**

- Manufacturer's name, in this case "H&K", or the registered trademark.
- The type of ammunition that can be shot from this weapon.
- A unique consecutive manufacturing number.

**Regulations**

- All weapons that are produced in Germany require the same markings due to legal weapons regulations.
- The marking of weapons that were produced abroad as part of a license-production is regulated by the national laws and regulations of that country.
- The markings of H&K weapons are carried out in agreement and under the control of the official Bureau for firearms and explosives, the "Beschussamt".

Source: Information obtained from Heckler & Koch (June 2007) and translated by Christine Beck.



## 5.4 Marking of already produced SALW

Large numbers of inadequately marked SALW are currently stored in military, official, dealers' and manufacturers' stockpiles all over the world. To help prevent them from "leaking" into the civilian market it is strongly recommended that appropriate identifiers to register weapons that are brought out of stockpiles into active service or are transferred to the civilian market or other destinations are applied<sup>12</sup>. As the marking of already manufactured weapons can be a costly affair, alternative means of marking could be used, as outlined in Box 6 below.

<sup>12</sup> Tracking Lethal Tools. Marking and Tracing Arms and Ammunition: a central piece of the arms control puzzle, by Amnesty International, Oxfam, and IANSA (International Action Network on Small Arms), for the Control Arms Campaign, p.10, [http://www.oxfam.org.uk/what\\_we\\_do/issues/conflict\\_disasters/downloads/tracking\\_lethal\\_tools.pdf](http://www.oxfam.org.uk/what_we_do/issues/conflict_disasters/downloads/tracking_lethal_tools.pdf)

A large grid of dots for taking notes, consisting of 30 rows and 50 columns of small, light gray dots.

### Box 6: Marking of weapons recovered during “Weapons for Development Programmes”—case study Sierra Leone

To overcome the fact that a large number of weapons recovered during weapons collection programs were locally made and therefore did not have a serial number, the UNDP Arms for Development Project in Sierra Leone produced their own “serial numbers” on stickers. One sticker was placed on each collected weapon, and this number appeared on all forms and receipts that were given to both the police and the owner.

The same procedure could be applied to weapons that have already been manufactured but have not yet been marked.

**Exercise 4:** Marking weapons with stickers (see Box 6 above) is rather a temporary solution than a permanent means to mark small arms, as stickers are removable. What alternative methods can you think of?



A large grid of dots for taking notes, consisting of 30 rows and 50 columns of small, light gray dots.

## Section 2 Record-keeping and SALW databases

### Objectives of Section 2:

By the end of this section, each trainee should have:

- An understanding of the importance of record-keeping in the marking and tracing process, and the relevant standards set by the M&TI.
- A good overview of a variety of existing practices and means of record-keeping of marked SALW.

**Note: The marking of SALW is only useful when the marked weapon is then registered into a (national) database recording basic information on the weapon and its history, beginning with its manufacture.** Record-keeping is therefore a crucial element, as the collection and maintenance of data facilitates the identification of a weapon, its legal status and the location of its storage, at a given stage of its life. Equally important is the timely and easy access of this information that is usually held by sub-national authorities, for example by a national tracing point of contact.

Records can be entered and kept either manually or electronically in databases.



A large area of the page is filled with a light gray dot grid pattern, intended for taking notes.

## 1. Benefits of record-keeping

**Exercise 1:** What information should records contain? Discuss in small groups and write your answers into the box below (second from right).



Causal chain chart: benefits of record-keeping

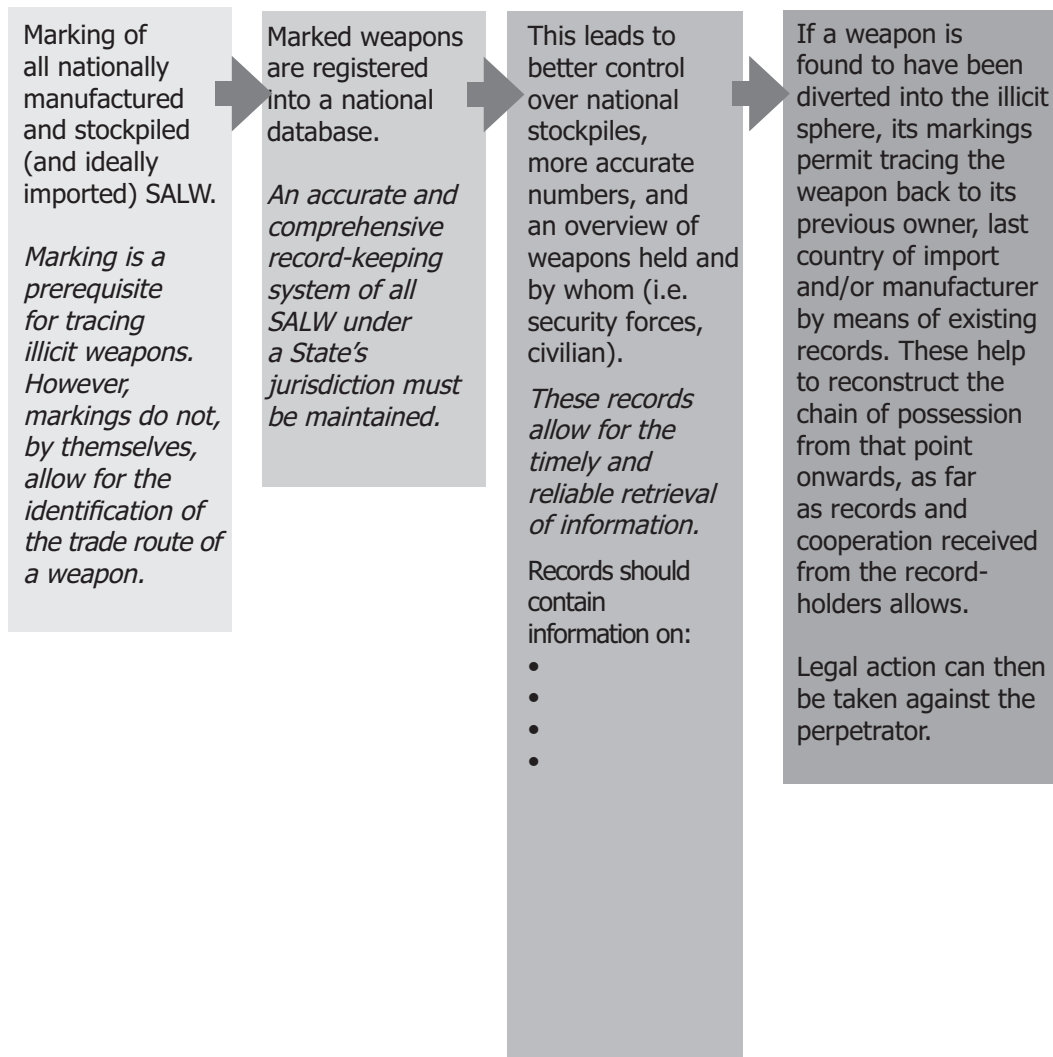

A large grid of small dots for taking notes, consisting of 30 rows and 50 columns.



**Box 1: UN M&TI, Excerpt from Section IV, Record-keeping (paragraphs 11-13)**



11. The choice of methods for record-keeping is a national prerogative. ...
12. From the time of the adoption of this instrument, records pertaining to marked small arms and light weapons will, to the extent possible, be kept indefinitely, but in any case a State will ensure the maintenance of:
- (a) Manufacturing records for at least 30 years; and
  - (b) All other records, including records of import and export, for at least 20 years.
13. States will require that records pertaining to small arms and light weapons held by companies that go out of business be forwarded to the State in accordance with its national legislation.

Source: International Instrument to Enable States to Identify and Trace, in a Timely and Reliable Manner, Illicit Small Arms and Light Weapons (UN M&TI), p.4, [http://www.un.org/events/smallarms2006/pdf/international\\_instrument.pdf](http://www.un.org/events/smallarms2006/pdf/international_instrument.pdf)



## 2. Challenges of record-keeping

As was illustrated in Section 1, markings of SALW are important and necessary to identify the point of manufacture of a weapon. But only in combination with the accurate registration of all manufactured and nationally stockpiled (and ideally imported) SALW can the necessary information, and in particular a weapon's transfer and re-transfer routes be provided that is needed to trace the supply chain of that particular weapon.

However, **even where accurate records exist, they are often scattered, as manufacturers, dealers or exporters hold some information, while customs and/or other authorities or ministries keep other information.** As many national systems still rely on paper-based documentation, information on different documents, such as payment invoices and receipts or cargo manifests and waybills, is usually not cross-referenced<sup>13</sup> and often not easily accessible due to a fragmented system of record-keeping. This can have an impact on the timely and reliable retrieval of information needed for tracing a weapon.

**Note:** The identification and registration of SALW and ammunition items takes a considerable amount of time.



<sup>13</sup> Tracking Lethal Tools. Marking and Tracing Arms and Ammunition: a central piece of the arms control puzzle, by Amnesty International, Oxfam, and IANSA (International Action Network on Small Arms), for the Control Arms Campaign, p.13, [http://www.oxfam.org.uk/what\\_we\\_do/issues/conflict\\_disasters/downloads/tracking\\_lethal\\_tools.pdf](http://www.oxfam.org.uk/what_we_do/issues/conflict_disasters/downloads/tracking_lethal_tools.pdf)

A large grid of dots for taking notes, consisting of 30 rows and 50 columns of small, light gray dots.

**Exercise 2:** What are potential difficulties and challenges of record-keeping? Discuss in small groups.



**Note:** With a number of issues relating to marking and tracing and their implementation, the OSCE Best Practice Guide goes into more detail than the UN M&TI. We therefore recommend you to consider this guide as a complementary document to the UN M&TI.



## Box 2: Different registration levels—OSCE Best Practice

### When to register weapons:

#### 1. States should refer to the following record-keeping scheme, to be followed in accordance with their own legal system.



- i) **At manufacture:** A record should be kept by the manufacturer of SALW produced (see OSCE Best Practice Guide on National Controls over Manufacture of Small Arms and Light Weapons, downloadable from: [http://www.osce.org/publications/fsc/2003/12/13550\\_30\\_en.pdf](http://www.osce.org/publications/fsc/2003/12/13550_30_en.pdf))
- ii) **At testing:** If a State participates in a proof-testing regime for SALW, a record of testing for each individual weapon should be kept by the agency conducting the testing.
- iii) **At import:** The importer of SALW or other designated body should maintain a record of every weapon imported at the time of entry into the country (see OSCE Best Practice Guide on Export Control of Small Arms and Light Weapons [http://www.osce.org/publications/fsc/2003/12/13550\\_34\\_en.pdf](http://www.osce.org/publications/fsc/2003/12/13550_34_en.pdf))
- iv) **At commercial sale:** The retailer should keep and maintain a record of every weapon sold from its inventory or submitted to any other operation in its installation.
- v) **At possession:** A record should be kept of the allocation of SALW to a public department. This record could also be kept by authorities issuing holding authorizations for other persons (see OSCE Best Practice Guide on National Procedures for Stockpile Management and Security, [http://www.osce.org/publications/fsc/2003/12/13550\\_32\\_en.pdf](http://www.osce.org/publications/fsc/2003/12/13550_32_en.pdf))
- vi) **In case of loss or theft:** A record should be kept of lost or stolen weapons to facilitate prompt notification of national competent authorities (see OSCE Best Practice Guide on National Procedures for Stockpile Management and Security, [http://www.osce.org/publications/fsc/2003/12/13550\\_32\\_en.pdf](http://www.osce.org/publications/fsc/2003/12/13550_32_en.pdf))
- vii) **At destruction:** A record should be maintained of weapons destroyed at the direction of competent national authorities by those carrying out the destruction (see OSCE Best Practice Guide on National Procedures for the Destruction of Small Arms and Light Weapons, [http://www.osce.org/publications/fsc/2003/12/13550\\_36\\_en.pdf](http://www.osce.org/publications/fsc/2003/12/13550_36_en.pdf))

A large grid of dots for taking notes, consisting of 30 rows and 50 columns of small, light gray dots.

All the above information shall be made available to the competent national authorities if requested by national law.

## **2. Registers**

All registers used for record-keeping should be appropriately authenticated. States shall assure the maintenance for as long as possible, and no less than ten years, of the information necessary to trace and identify SALW to enable them to carry out successful tracing. If entities other than governmental bodies are authorized to maintain certain records, they shall ensure the conservation of the above-mentioned information for as long as they perform this activity. On completion of this function, those entities shall transmit the registers in their possession to the competent governmental authority or to the dealer taking over this activity.

## **3. Nature of registered information**

The information to be recorded at the stages mentioned above should, at a minimum, include for each weapon:

- The identification marking.
- A precise description of the weapon, notably its type and model.
- All additional, possibly coded, information affixed on the weapon.

As appropriate, a record could be kept of the origin and destination of the weapon and, eventually, of the export or import licences.

## **4. Non-registered SALW**

Non-registered SALW, where legally held, should be submitted to official regulation. The competent authority would then be responsible for recording their possession. If those fire-arms weapons are not properly marked, they should be recorded at the time of regularization marking.

Illicitly manufactured or trafficked SALW may only be regularized if approved by a competent legal authority, and for a specific purpose, such as for museums or law enforcement training. States shall adopt the necessary measures to ensure that all SALW seized, confiscated, or forfeited as the result of illicit manufacturing or trafficking do not fall into the hands of unauthorized persons or entities.

Source: Best Practice Guide on Marking, Record-keeping and Traceability of Small Arms and Light Weapons, pp.8-9, [http://www.osce.org/publications/fsc/2003/12/13550\\_29\\_en.pdf](http://www.osce.org/publications/fsc/2003/12/13550_29_en.pdf)

A large grid of dots for taking notes, consisting of 30 rows and 50 columns of small, light gray dots.

**Exercise 3:** What information is needed for a weapon's registry form? Design a registry form. Work in groups.



**Trainee Note**

If IT resources are limited, all records can be held manually in binders. Or else, information can be kept in an EXCEL sheet on your computer or by means of an electronic software programme. There are also some useful model forms or samples of firearm registration requirements that can be used: electronic resources include the Firearms Reference Table FRT, produced by the Royal Canadian Mounted Police (FRT Section, Forensic Laboratory Services. PO Box 8885. Ottawa, Ontario, CANADA. K1G 3M8. Email: FRT-TRAF@rcmpgrc.gc.ca), or the OSCE Handbook of Best Practices on Small Arms and Light Weapons (<http://www.un.org/Docs/sc/committees/1373/handbook.pdf>).

No matter what type of record-keeping you choose, ensure the following information is included:

- Identify weapon (weapon class, e.g. assault rifle, etc).
- Identify weapon type\* (G3, M16, etc.).
- Country of manufacture.
- Serial number\*.
- Manufacturer's mark.
- Batch mark.
- Owner's mark.

(\* a must)

You may want to add where the weapon in question was found, if it is licensed, etc.

**Note:** Manual accounting is not a problem; however it can be a labor-intensive task to input all the data accurately into a database.

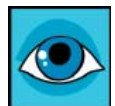

A large grid of dots for taking notes, consisting of 30 rows and 50 columns of small, light gray dots.



## Section 3 Tracing SALW

### Objectives of Section 3:

By the end of this section, each trainee should have:

- A good understanding of how marking, record-keeping and tracing interlink and depend on each other and the relevant standards in the M&TI.
- A good overview of the purpose and procedures of tracing.

### 1. Benefits of tracing SALW

**Exercise 1:** What is the objective of tracing (often illicit) weapons? What are some reasons for tracing? Discuss in small groups and record your answers in the chart below.



Marking and accurate record-keeping are mandatory for the reliable tracing of a weapon. Weapons can be traced within the framework of a **criminal investigation** or within the framework of weapons seizures. Its main purpose is to provide a trail of ownership which can assist in two activities:

- To conduct a criminal investigation (when and where the weapon might have been used).
- To contribute to prevent the spread of illicit weapons by tracing sources of diversion.

To trace a weapon, the national weapons registers will need to be checked for the weapon recovered or seized, and if it cannot be found in there, it can be assumed that the weapon in question must have been illicitly imported. If the recovered weapon has markings, the country that recovered the weapon (country A) can approach the country of origin (country B), or the last country of import (country C), and can request cooperation in tracing the weapon back to its manufacturer including all intermediate owners (see Annex VI Tracing process of a recovered weapon). Using existing records, country B can reconstruct the transfer chain of the weapon circulated under its jurisdiction. Cooperation in tracing is a crucial element that needs to be strengthened, as it could contribute substantially towards the prevention of the trade and diversion of illicit SALW.

Effective tracing would not only contribute to improving security within a country, but would also prevent the spread of illicit weapons to neighboring countries, and thus have an impact at the international level. The effectiveness of tracing at the international level hence very much depends on the measures taken at the national level and can only be effective if such integrated measures are in place (see Figure 1, Section 5).

Tracing enables governments to track these sources of diversion (see Annex VIII From producer to consumer). Sources can include corrupt individuals, police institutions or

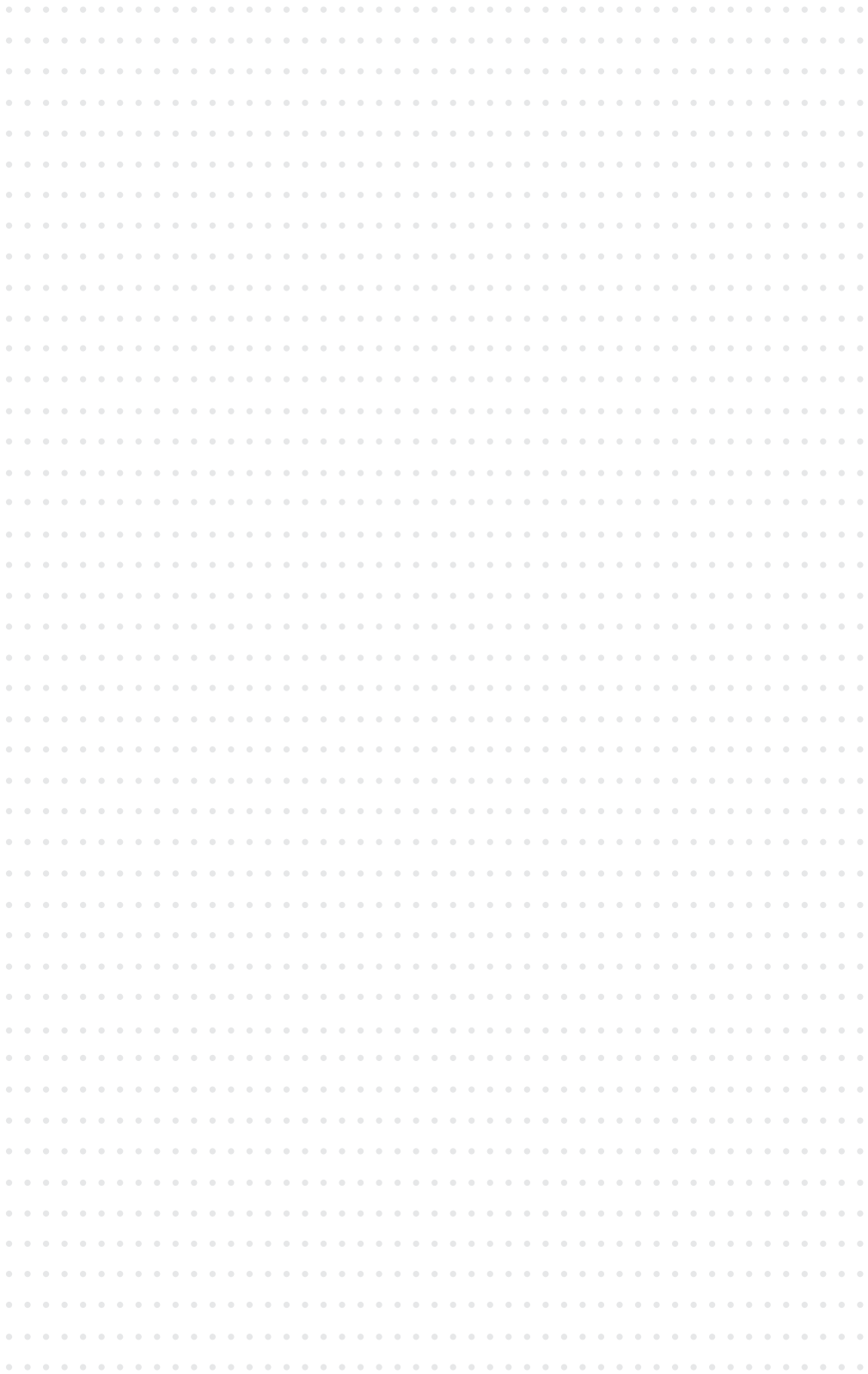

other forms of diversion, such as through brokers that may have played a role in the weapon's illicit proliferation. Identifying these sources can enable legal action or assist in the decision to use another broker.

Box 1: UN M&TI, Excerpt from Section V, Cooperation in tracing (paragraphs 14–23)



**General**

14. While the choice of tracing systems will remain a national prerogative, States will ensure that they are capable of undertaking traces and responding to tracing requests... .

15. States receiving information related to tracing illicit small arms and light weapons in accordance with the provisions of this instrument ... will guarantee the confidentiality of such information. Restrictions on use may include, inter alia:

- (a) The information exchanged will be released only to competent authorities designated by the requesting State and/or authorized personnel, ...;
- (b) The information exchanged will be used only for purposes consistent with this instrument; or
- (c) The information exchanged may not be released to anyone else without the prior consent of the State providing that information.

...

**Tracing requests**

16. A State may initiate a tracing request in relation to small arms and light weapons found within its territorial jurisdiction that it considers to be illicit... .

17. To ensure smooth and effective cooperation in tracing, requests for assistance in tracing illicit small arms or light weapons will contain sufficient information, including, inter alia:

- (a) Information describing the illicit nature of the small arm or light weapon, including the legal justification therefore and, to the extent possible, the circumstances under which the small arm or light weapon was found;
- (b) Markings, type, calibre and other relevant information to the extent possible;
- (c) Intended use of the information being sought.

**Responses to tracing requests**

18. States will provide prompt, timely and reliable responses to tracing requests made by other States.

19. States receiving a tracing request will acknowledge receipt within a reasonable time.

...

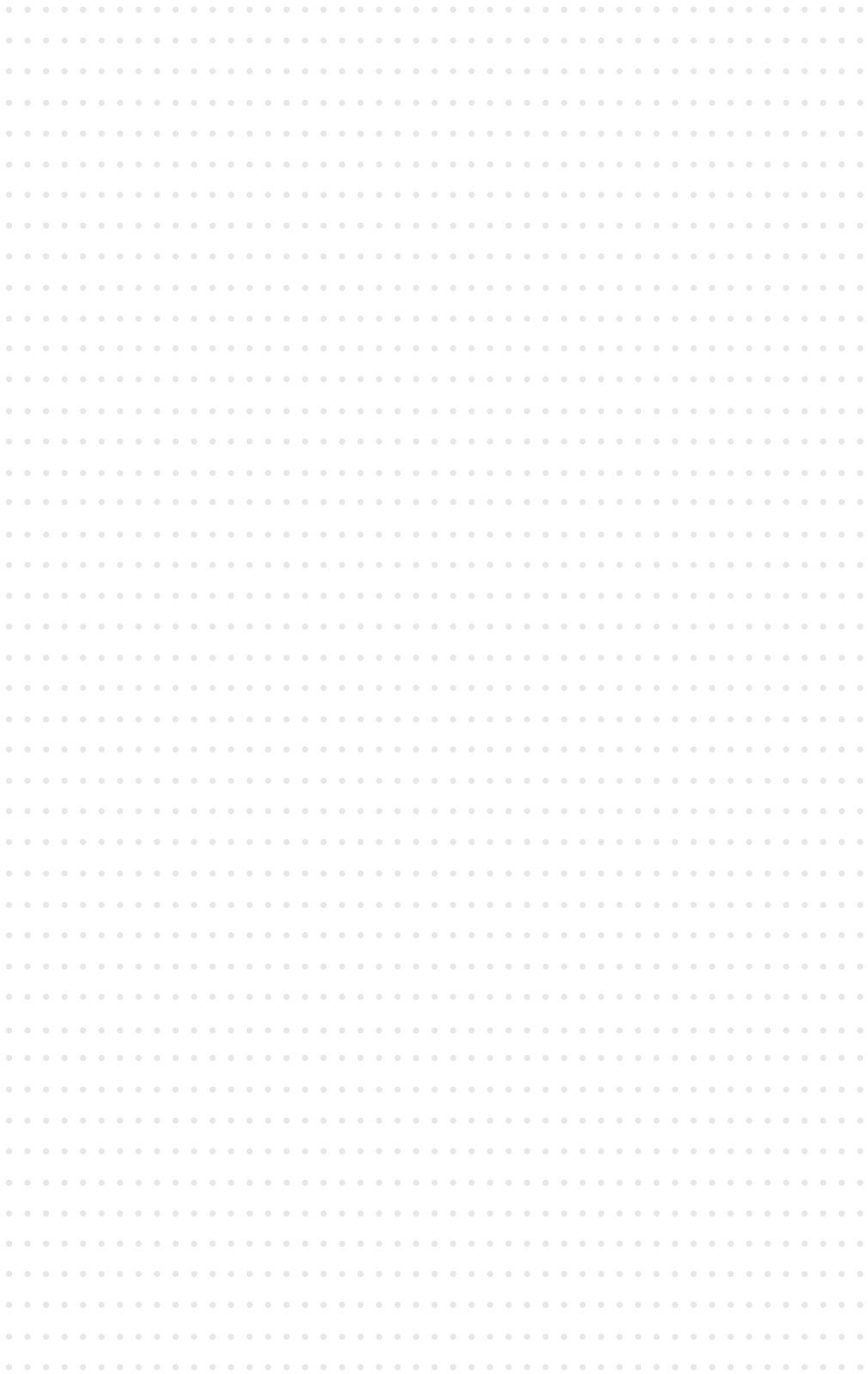

22. States may delay or restrict the content of their response to a tracing request, or refuse to provide the information sought, where releasing the information would compromise ongoing criminal investigations or violate legislation ... .

Source: International Instrument to Enable States to Identify and Trace, in a Timely and Reliable Manner, Illicit Small Arms and Light Weapons (UN M&TI), pp.4-5, [http://www.un.org/events/smallarms2006/pdf/international\\_instrument.pdf](http://www.un.org/events/smallarms2006/pdf/international_instrument.pdf)

Causal chain chart: benefits of tracing

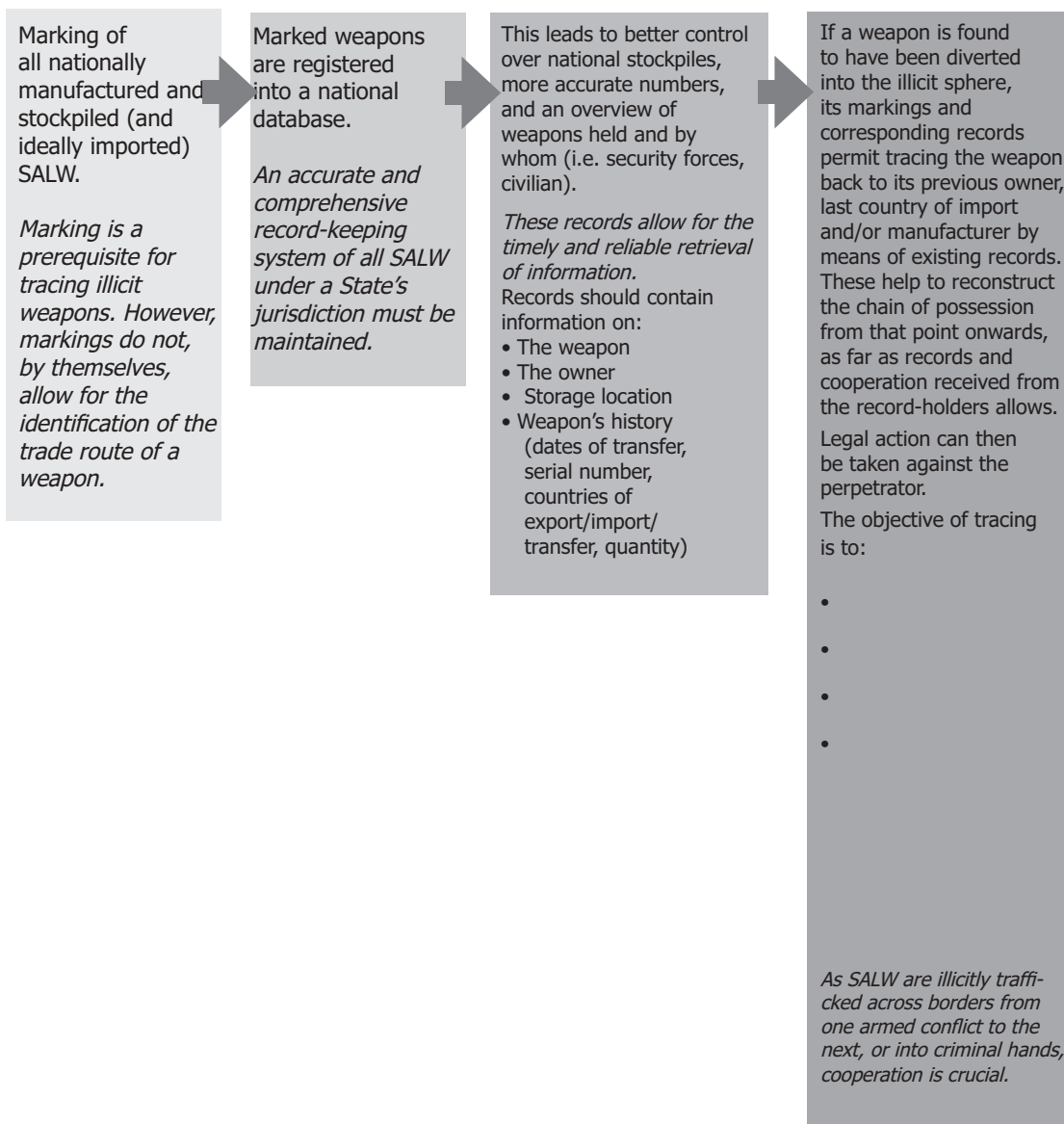

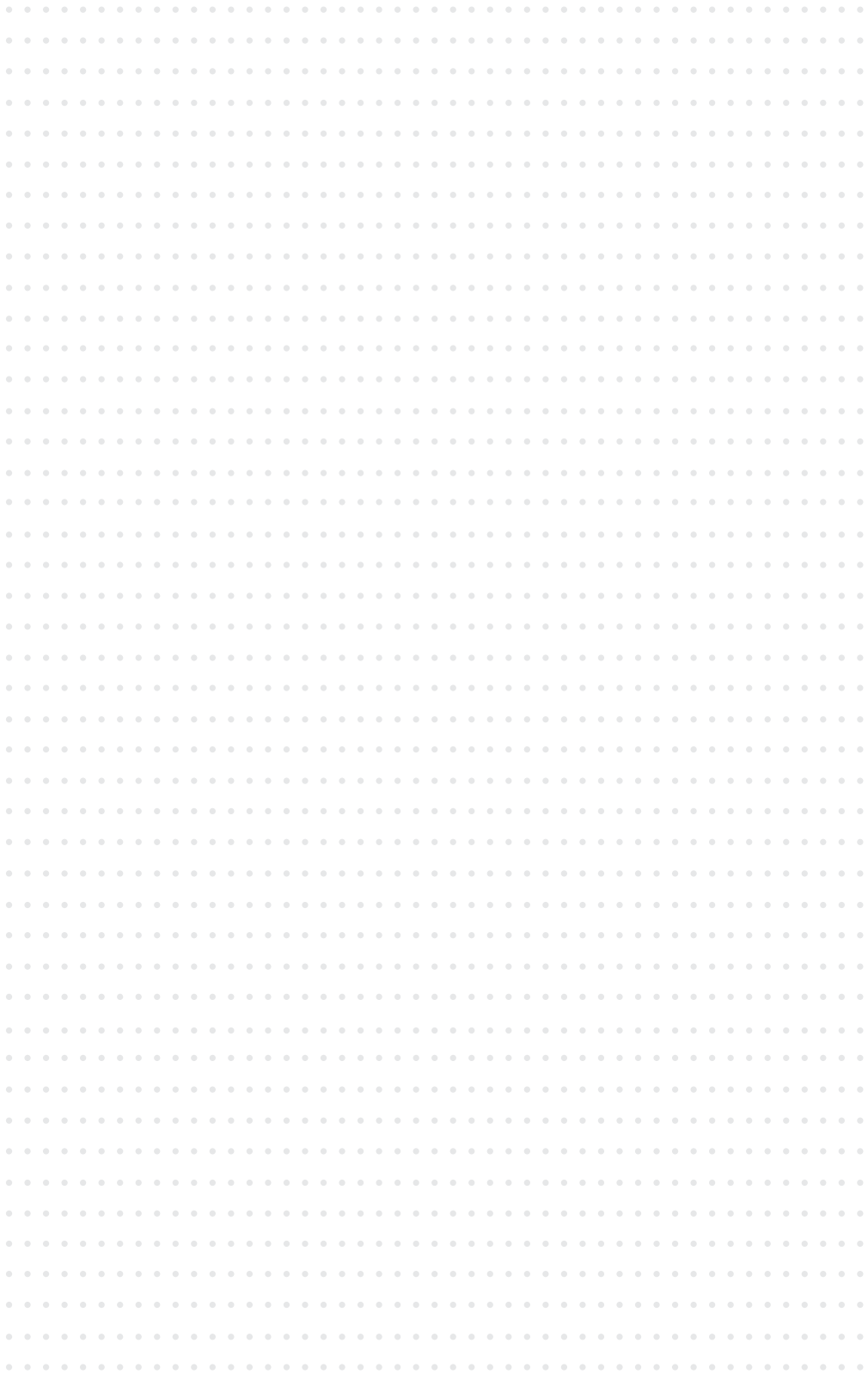

## 2. Interpol's role

**As regards the tracing of weapons used in crime**, the PoA, the UN Firearms Protocol and the UN M&TI all support the role of Interpol in facilitating cooperation in tracing and encourage support for the Interpol Weapons Electronic Tracing System (IWeTS).

### Box 2: UN M&TI, Excerpt from Section VI, Implementation International Criminal Police Organization

33. States, where appropriate, will cooperate with the International Criminal Police Organization (Interpol) to support the effective implementation of this instrument.

34. States that are members of Interpol will promote the implementation of this instrument when participating in Interpol's organs.

35. States, where appropriate, in accordance with Interpol's statutory rules, are encouraged to make full use of Interpol's mechanisms and facilities in implementing this instrument. Interpol may, at the request of the concerned State, assist in the following areas:

- (a) Facilitation of tracing operations conducted within the framework of this instrument;
- (b) Investigations to identify and trace illicit small arms and light weapons;
- (c) Wherever possible, building national capacity to initiate and respond to tracing requests.



## Interpol

Interpol is the world's largest international police organization, with 186 member countries. It facilitates cross-border police cooperation, and supports and assists all organizations, authorities and services whose mission is to prevent or combat crime.

### **Interpol's initiatives relating to SALW**

Interpol has two major initiatives relating to conventional weapons (firearms and explosives): the **Orange Notice** and the **Interpol Weapons Electronic Tracing System (IWeTS)**.

#### **Orange Notice**

Based on requests from the National Central Bureaus (NCBs) or international organizations with which Interpol has special agreements, the Interpol General Secretariat produces notices in all of the organization's official languages (Arabic, English, French and Spanish) which are color coded. An **Orange Notice** provides a warning about weapons when there is reason to believe that it will help law enforcement and security officials identify a threat they might not normally detect. This generally involves firearms, especially small arms. The notices' goal is twofold:





- To make it easier for law enforcement officers in all member countries to trace firearms which have moved internationally.
- To increase the content of Interpol's databases with firearm trace recovery data from NCBs, which will expand the organization's ability to support weapons trafficking investigations.

Additionally, Interpol plans to add features, which will enhance law enforcement officers' capacity to initiate successful firearm trace requests.

In 2006, the General Secretariat issued 4,556 notices; 9 of these were orange notices.

#### **Interpol Weapons Electronic Tracing System (IWeTS)<sup>14</sup>**

Interpol has been specifically mandated in Paragraph 35 of the "International Instrument to Enable States to Identify and Trace, In a Timely and Reliable Manner, Illicit Small arms and Light Weapons" to assist States with the:

- Facilitation of tracing operations conducted within the framework of this instrument  
and,
- Investigations to identify and trace illicit small arms and light weapons.

To meet this obligation Interpol designed the Interpol Weapons Electronic Tracing System known as IWeTS. In essence, this tool, combined with Interpol's communication system, will give the law enforcement agencies of Member States the capability to trace illicit firearms that are being seized through law enforcement activities in their countries.

Once operational, IWeTS is assumed to be a network linking the databases related to SALW of Member States to Interpol. In addition, IWeTS will also host a comprehensive library of most firearms in existence, facilitating the identification of such weapons used during an alleged crime. This combination will enable the law enforcement agencies to identify and trace such alleged illicit weapons.

The prototype of IWeTS is currently being developed using Interpol's I-24/7 computer system, linking it to the responsible agency in the US for law enforcement activities with regard to SALW, the Bureau of Alcohol, Tobacco, Firearms and Explosives (ATF).

By simply completing a template located on the I-24/7 dashboard screen, law enforcement officers are provided with an easy method for requesting and responding to a trace on firearms recovered during an investigation.

The value of such a system for the law enforcement agencies of Member States is that it will make it easier for law enforcement officers to launch a trace of a US firearm allegedly used in the commission of a crime. Once the system has been tried and tested, Interpol will approach other Member States that manufacture arms and attempt to negotiate their integration into IWeTS.

<sup>14</sup> Source: United Nations Conference to Review Progress made in the Implementation of the International Instrument to Enable States to Identify and Trace, in a Timely and Reliable Manner, Illicit Small Arms and Light Weapons, Position of the International Criminal Police Organization (Interpol), Report by: The Office of the Special Representative of Interpol, to the United Nations, 29 June, 2006, <http://www.un.org/events/smallarms2006/pdf/Interpol.pdf>

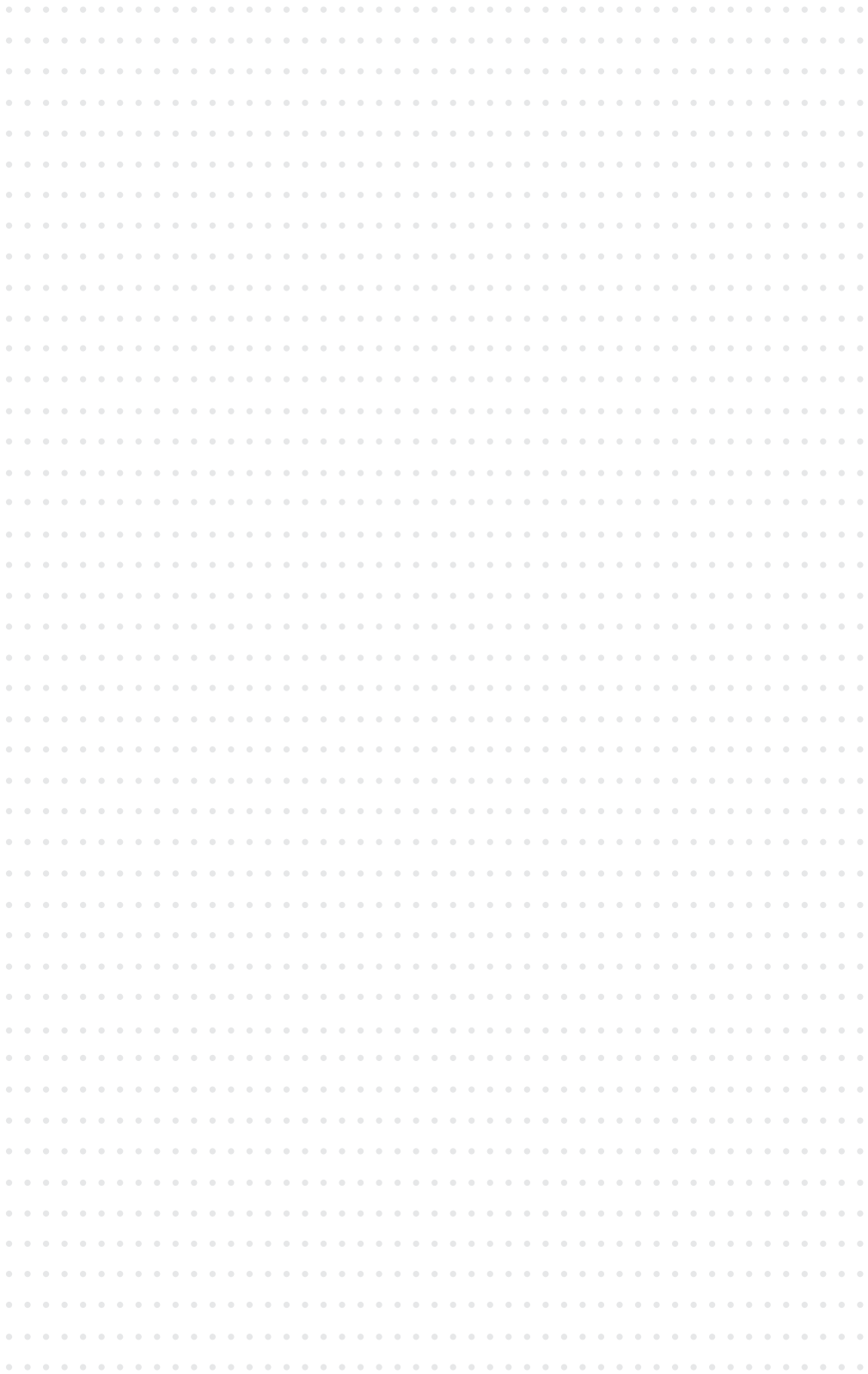

Screenshots of IWeTS

**Current Method for Tracing**

422 Message (Rich Text)

From: BUCDALI Henna  
To: WILHAMS Jan  
Cc:  
Subject: 422

Sent: Tue 3/20/2007 10:16 AM

From: NCB SOFIA Bulgaria  
Date: 2007/01/16 15:26  
To: NCB WIESBADEN Germany; ipsg@gs-igcs.int; ZONE IPCQ;  
Subject: 422  
IP SOFIA 422 16.01.2007 wi 2007/15147-1  
URGENT  
IP WIESBADEN  
IPCQ  
IPSG

Our Ref: A231/07/44  
Your Ref.: NEW CASE

SUBJECT: **Check of pistol** Exemplar cal. 22LR, serial Nr. 13382829 **inc**

Please be informed that the Sofia City police station is conducting an investigative case Nr. 556/2006 against unknown perpetrator in connection with art. 116 paragraph 1, point 11 and art. 115 of the Bulgarian penal code.

In the course of the investigation it was clarified that the weapon used for the commitment of the crime is pistol Exemplar cal. 22LR, serial Nr. 13382829, manufactured by "G. Anschütz" GmbH, Ulm West Germany.

In order to obtain all useful information and evidence concerning the case please provide us with the following information:

- Has such pistol ever been manufactured?
- When and whom it has been sold?
- Official data about it legal proprietors.
- Whether it has been involved in a crime at the territories of your countries.
- Any other relevant information.

Your prompt reply will be appreciated.

For all NCBS: Please provide you answer only in positive case.

11/20

Courtesy: INTERPOL

**Firearm information**

http://077.ip - IWeTS Form - Microsoft Internet Explorer provided by 1567 - GDFP INTERPOL

Information Owner Details	Recovery address	ID Documents	Summary
<b>Manufacturer (make)</b>	<input type="text"/>		<b>Weapons</b>
<b>Firearm type</b>	<input type="text"/>		
<b>Caliber / range</b>	<input type="text"/>		
<b>Model</b>	<input type="text"/>		
<b>Serial number</b>	<input type="text"/>		
<b>Barrel length</b>	<input type="text"/>		
<b>Finish</b>	<input type="text"/>		
<b>Importer</b>	<input type="text"/>		

Add Weapon  
Finish Reset

15/20

Courtesy: INTERPOL

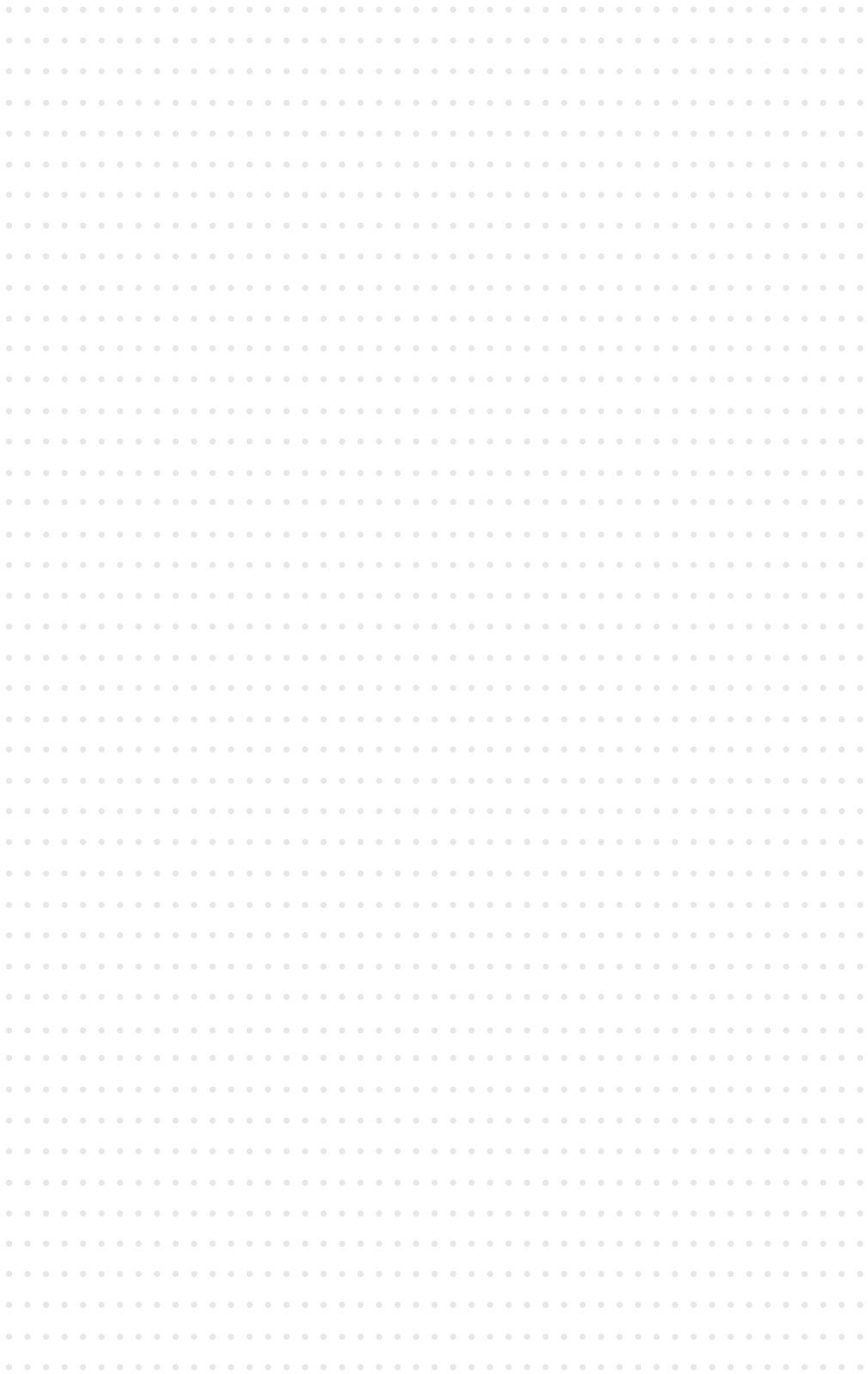

To live up to the second aspect of the mandate, the identification of illicit SALW, Interpol will make available to the law enforcement services of Member States the Firearms Reference Table (CFRT) developed by the Royal Canadian Mounted Police (RCMP). This product is not only the most comprehensive of its kind, but is also updated continually.

The CFRT provides the officer the opportunity to make a correct identification of the seized firearm prior to submitting the firearm for tracing. Used in conjunction with IWeTS, Interpol will be able to offer its users a web-based solution to identify and trace illicit SALW.

### **Benefits to Member States using IWeTS**

There are also other incidental benefits for the law enforcement community to digitalizing the process in identifying and tracing illicit SALW. In essence these benefits mean that while a Member State submits a firearm trace via the I-24/7 system:

- The name of the individual from whom the firearm, alleged to have been used in the commission of a crime, has been seized, will be checked against Interpol's nominal database for known criminals.
- The firearms will be checked to see if they have been reported lost, or stolen in any other Member State,
- Should the individual suspected of having committed an offence possess a passport, that passport too will automatically be checked through the Interpol stolen and lost travel documents database.
- Should such a person possess a vehicle, this will automatically also be checked through the Interpol Stolen Vehicle database.

Member States are automatically notified if any of these queries reveal any information in the Interpol databases. Interpol will benefit by populating its databases with information related to crime, gained from Member States requesting the tracing of firearms. Four countries; South Africa, Brazil, Tunisia and Czech Republic have been identified as candidates to run the first IWeTS pilot programs, predominantly to verify the integrity of the systems and procedures. Once feedback from these pilot programs has been collected and analyzed, IWeTS will be systematically made available to other member states.

The final phase of IWeTS will be to connect Interpol's I-24/7 system to the various databases on illicit SALW maintained by other weapon manufacturing Member States. This will allow Member States to use Interpol as a crucial central point for identifying and tracing of firearms throughout the international law enforcement community.

Source: United Nations Conference to Review Progress made in the Implementation of the International Instrument to Enable States to Identify and Trace, in a Timely and Reliable Manner, Illicit Small Arms and Light Weapons, Position of the International Criminal Police Organization (Interpol), Report by: The Office of the Special Representative of Interpol to the United Nations, 29 June, 2006, <http://www.un.org/events/smallarms2006/pdf/Interpol.pdf>

For more detailed information on Interpol, see Interpol Fact sheets, <http://www.interpol.int/Public/ICPO/FactSheets/Default.asp>

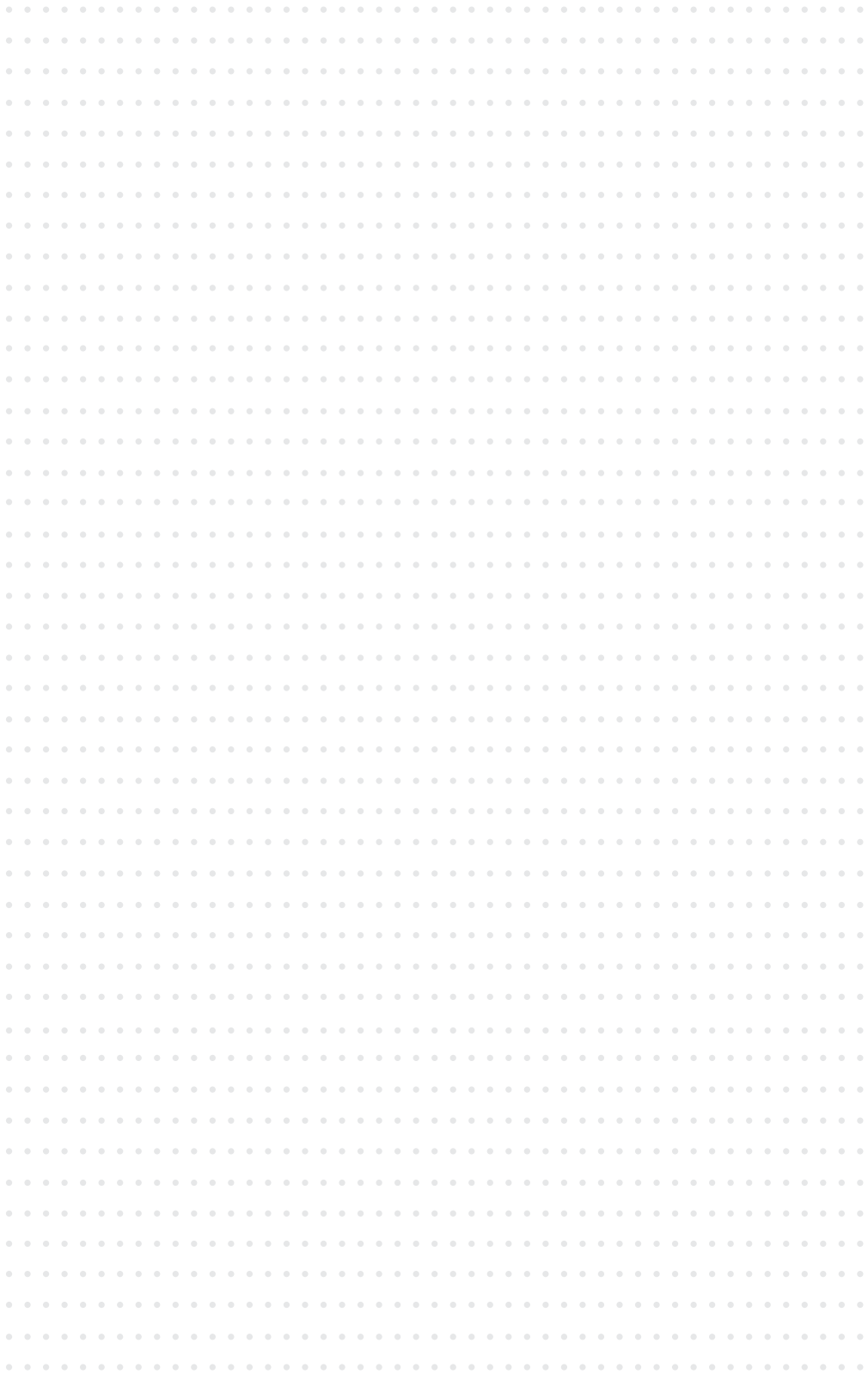

### 3. Challenges of tracing weapons

As discussed in Section 2 and above, a number of databases already exist or are, as in the case of IWeTS, being developed. While these systems certainly are valuable additions to the process of tracing, they have several shortcomings:

- The Canadian Firearms Registry is a weapons identification system, but not a tracing tool.
- DREAM is usually used for data collection within the framework of DD&R (Disarmament, Demobilization and Reintegration) programs. To date, no practical experience exists of DREAM being used as an electronic weapons record-keeping system.
- IWeTS is limited to criminal weapons and does not apply to conflict-related weapons. While IWeTS will in the future enable a police officer to add a weapon into the database and place a tracing request, the tool will not be able to help identify the diversion of a weapon.

Other challenges to tracing include:

- The lack of a legally binding framework for cooperation on tracing. Despite this absence, the UN M&TI provides a political framework containing firm commitments in this area, though with some exceptions. For example, paragraph 22 specifies the reasons for which States may withhold tracing cooperation, while paragraph 23 will make it clear, at least to the state requesting tracing cooperation, whether the requested state is applying paragraph 22 in good faith or not (see Box 3 below).
- Lack of institutionalized processes for tracing illicit weapons and finding out how these weapons got lost or were diverted into different regions, can weaken international efforts to tackle the illicit SALW problem.
- Absence of a central registry. When different law enforcement agencies, manufacturers and/or Ministries all operate their own weapons registers, tracing a weapon can become difficult and time consuming, as the weapon in question would have to be searched within all individual registers. Where registers are not easily accessible between different agencies, the tracing process would slow down considerably.
- Lack of capacity to engage in tracing. This includes the lack of material, financial and human capacity to engage in this activity.
- Lack of political will. This includes the lack of will to initiate and/or respond to a tracing request. Due to its non-binding character, there may also be a lack of political will to implement the M&TI at the national level.





**Box 3: UN M&TI, Excerpt from Section V, Cooperation in tracing, paragraphs 22-23**



22. States may delay or restrict the content of their response to a tracing request, or refuse to provide the information sought, where releasing the information would compromise ongoing criminal investigations or violate legislation providing for the protection of confidential information, where the requesting State cannot guarantee the confidentiality of the information, or for reasons of national security consistent with the Charter of the United Nations.

23. If a State delays or provides a restricted response to a tracing request, or refuses to provide the information sought, on the grounds identified in paragraph 22 above, it will inform the requesting State of the reasons for this. The requesting State may subsequently seek clarification of this explanation.



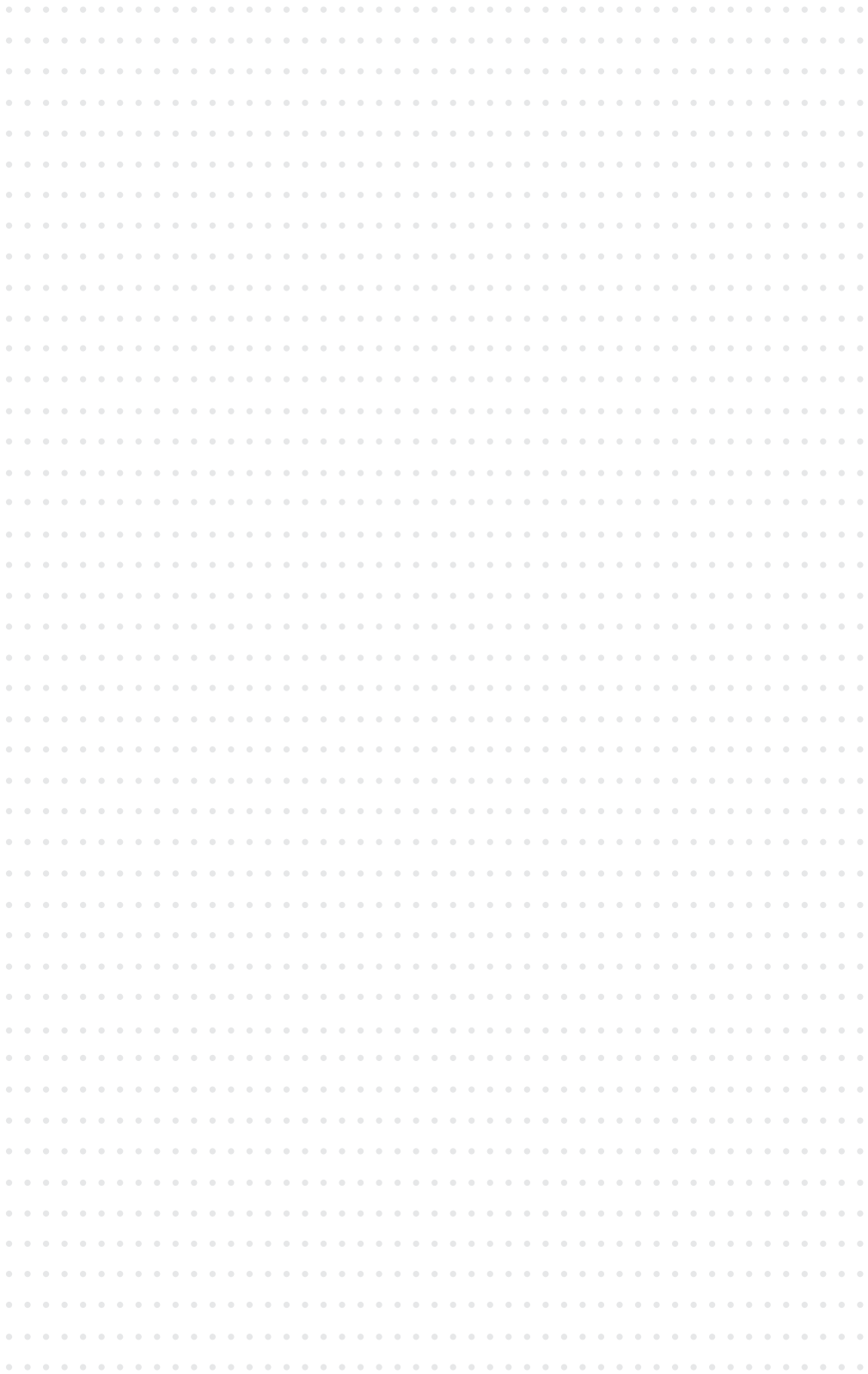

## Section 4 Marking and tracing of small arms ammunition

Small arms ammunition is not included within the UN M&TI. At present, the vast majority of States have a limited capacity to trace small arms ammunition recovered in the illicit sphere.

### **Exercise 1:**

A box of ammunition has just been recovered in a border area of your country. As a government official, you are asked to find out where it came from, who it belongs to, and how it got there. What type of information would you need for your investigation? Who would you approach for assistance? Brainstorm in small groups.



- Tracing would allow us to **reliably identify** the **origins** and **transfer chain** of the ammunition from the legal to the illicit sphere;
- This could improve the ability of States to **pinpoint** and **prevent sources of diversion** within the legal transaction chain, as well as to combat illicit ammunition flows and transfers;
- Focusing on **ammunition is critical** to combating the devastation caused by small arms proliferation and misuse. Without ammunition, weapons would not be deadly.

Imagine that an ammunition cartridge or a package of ammunition is recovered from the scene of an armed attack/criminal act. At minimum, States and State authorities are able to:

- Identify the manufacturer / country of manufacture of the ammunition;
- Identify the caliber.

But how did the ammunition get there? Who used it? How do we prevent this from happening again? To answer these questions, we need to be able to follow the route of the ammunition from its production to use—in other words, we need to be able to trace the ammunition.

**Note: Tracing is a function of good marking and record-keeping practices.**



Adequate marking and record-keeping of ammunition allows States and State authorities to:

- Identify the first and subsequent recipients of the ammunition—this requires information to whom the manufacturer's ammunition was sold, and to whom it was subsequently transferred.
- Identify the last legal holder of the ammunition—if this is not the perpetrator of the crime, such information may help clarify the point at which the ammunition was diverted into the illicit sphere.

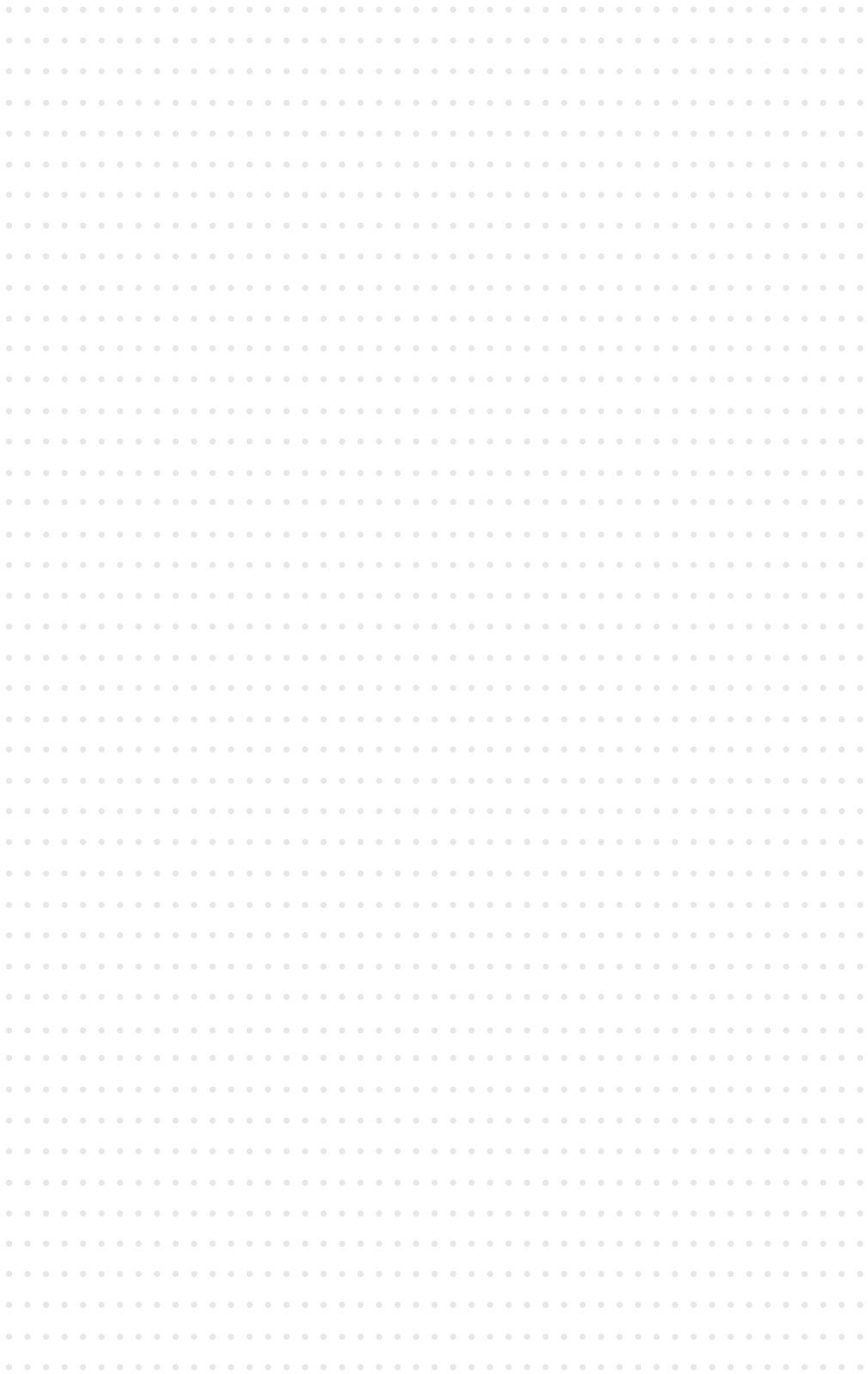

## 1. Marking small arms ammunition<sup>15</sup>

Marking small arms ammunition is not a new concept or practice—a number of States around the world have incorporated ammunition marking standards in their military sector.<sup>16</sup> These standards often dictate the technical and safety requirements of ammunition produced for their armed forces, including the markings a manufacturer must apply to ammunition bodies and ammunition packaging.<sup>17</sup>

One of the main purposes of these markings is safety: not only does ammunition have a shelf life<sup>18</sup>, but some may be defective at manufacture. In this context, applying markings on ammunition allows:

- the user/customer to identify the manufacturer and provide feedback on performance-related problems, and;
- the manufacturer to identify the ammunition 'lot' and investigate the components that were used in that production run for defects.

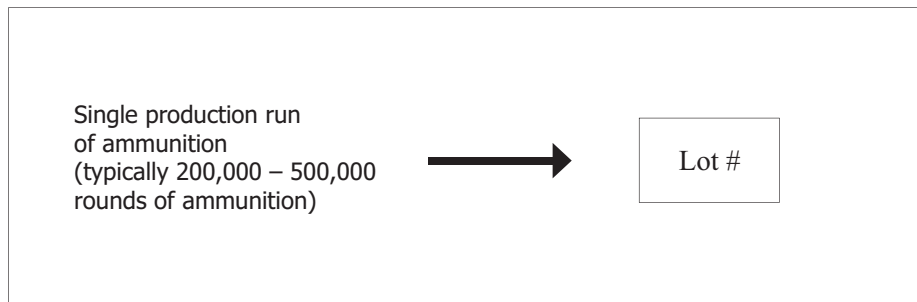

### 1.1 Marking ammunition packaging

Adopting a standard on small arms ammunition packaging could make a contribution toward preventing diversions, as some small arms ammunition recovered in the illicit sphere are found in their original packaging.<sup>19</sup>

A standard requirement for ammunition produced for national armed forces in NATO member States and other countries is to mark ammunition packages with the following information:

- Lot#
- Manufacturer identification
- Year of manufacture

<sup>15</sup> FEASIBILITY OF A SALW TRACING AGENCY IN GERMANY, Briefing on the SALW tracing system in the Federal Republic of Germany and scope for possible improvements, by Holger Anders

<sup>16</sup> This refers to ammunition with a calibre smaller than 12.7mm, which includes ammunition for pistols, revolvers, carbines, assault rifles, sub- and light-machine guns.

<sup>17</sup> Holger Anders, Targeting Ammunition, p.208

<sup>18</sup> While it is often assumed that ammunition has a short shelf life, in reality, the shelf life of ammunition depends wholly on the storage conditions of the cartridges, keeping them away from excessive moisture and heat. Even so, it is reported that even ammunition stored in adverse conditions is usable for 20-30 years. For more information, see Rachel Stohl, 1998

<sup>19</sup> Anders, p. 210

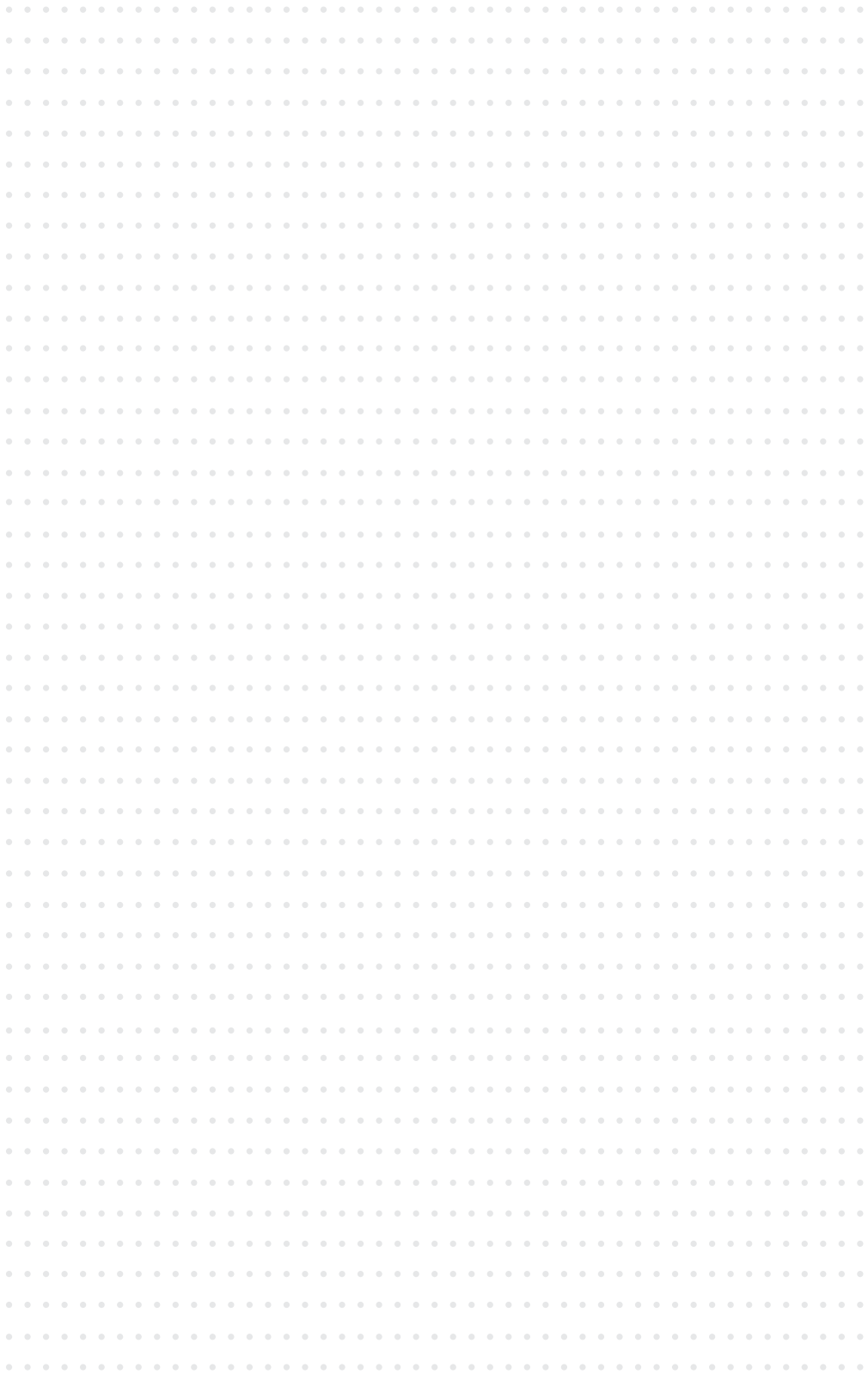

- Caliber of ammunition
- Quantity of ammunition

The same markings are applied to packaging of ammunition for **non-state actor markets** (sport shooters, hunters) in a number of States.<sup>20</sup>

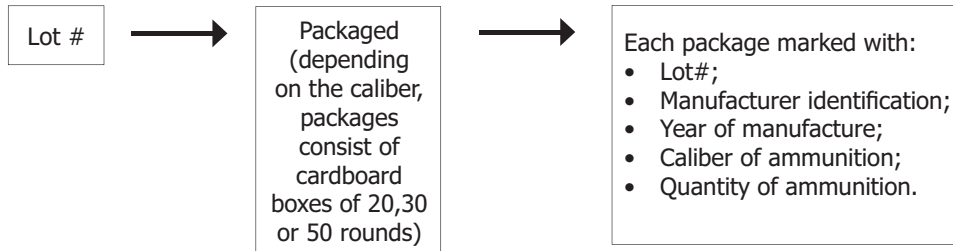

### Box 1: Marking ammunition and lots in Brazil

On 22 December 2003 the Brazilian Congress passed Federal Law No. 10,826, known as the Statute of Disarmament (specific technicalities were regulated on 1 July 2004 by Presidential Decree No 5123). This law was the result of a decade of campaigning for a federal law that would tighten controls on the circulation and use of small arms. It also includes provisions for stricter regulation of the small arms and ammunition industry.

Concerning the issue of ammunition marking, the new law establishes the following provisions:

- **The head stamps of cartridges produced in Brazil for the armed forces and state law enforcement and security agencies must include a lot number.** The regulation entered into force on 1 January 2005 for .40 and .45 calibre ammunition and in July 2005 for 5.56 x 45 mm; 7.65 x 51 mm and 9 mm Parabellum; .380, .38, .50, and 12 gauge cartridges (Ministério da Defesa, 2004, articles 4, 11 and 12).
- **The lot number identifies the police agency or armed service** that, by law can purchase lots of up to of 10,000 rounds. **These rounds are assigned to a single public legal entity with a unique lot number, and their lots are manufactured at their specific request.**

#### Ammunition production and marking

In Brazil there is a single small arms ammunition manufacturer, the Companhia Brasileira de Cartuchos (CBC), which dominates both public and private domestic markets. If, for instance, a lot of 10,000 rounds of 5.56 x 45 mm cartridges is manufactured by

<sup>20</sup> See Anders, p. 210





CBC for the Brazilian Army, that lot will be sold only to the army, and the lot number will be marked on the base of each cartridge using laser technology at the end of the production process<sup>21</sup>. It is marked, as shown in the photo below, within the groove of the ammunition case. **It is expected that lot numbers will help the police to identify patterns of ammunition leakages from the police or the military to organized crime** which is a very serious problem in Brazil.



CBC cartridge with engraved lot number, in this case "AAD53".

Photo credit: Departamento da Polícia Técnico Científica (DPTC), Polícia Civil do Estado do Rio de Janeiro.

It may be possible to identify reloaded ammunition as such because CBC original primers are marked with a letter 'V' (see photo below).

**Note:** Illicit ammunition reloading is currently only a minor problem in Brazil according to the police forensic analysts in the state of Rio de Janeiro. This is not surprising considering the easy availability of ammunition on the illegal market. However, the issue of ammunition reloading as an option for criminal organizations should be considered if supply flows are curtailed by the enforcement of new legal and control measures.<sup>22</sup>



<sup>21</sup> Information from a presentation by an officer of the Brazilian Army Directorate of Controlled Products at the Putting People First, Rio Meeting 'Regulating civilian ownership of weapons' organized by Humanitarian Dialogue, Viva Rio and Sou da Paz, Rio de Janeiro, 16–18 March, 2005.

<sup>22</sup> Interviews with forensic analysts at the Rio de Janeiro state or scientific and technical police, Rio de Janeiro, November 2005. According to the analysts, reloaded ammunition is only a minor and unrepresentative part of the ammunition they examine in the course of their work. Reloading is limited to revolver and pistol ammunition and is identified either by the primer capsule or, in the case of pistol ammunition, because the head does not have a full metal jacket as is the case for most of the pistol ammunition manufactured by CBC. According to Brazilian legislation, apart from law enforcement agencies and the armed forces, only the following entities are authorized to reload ammunition and own reloading machines: shooting clubs, authorized shooters, hunters, arms companies, and private security academies.

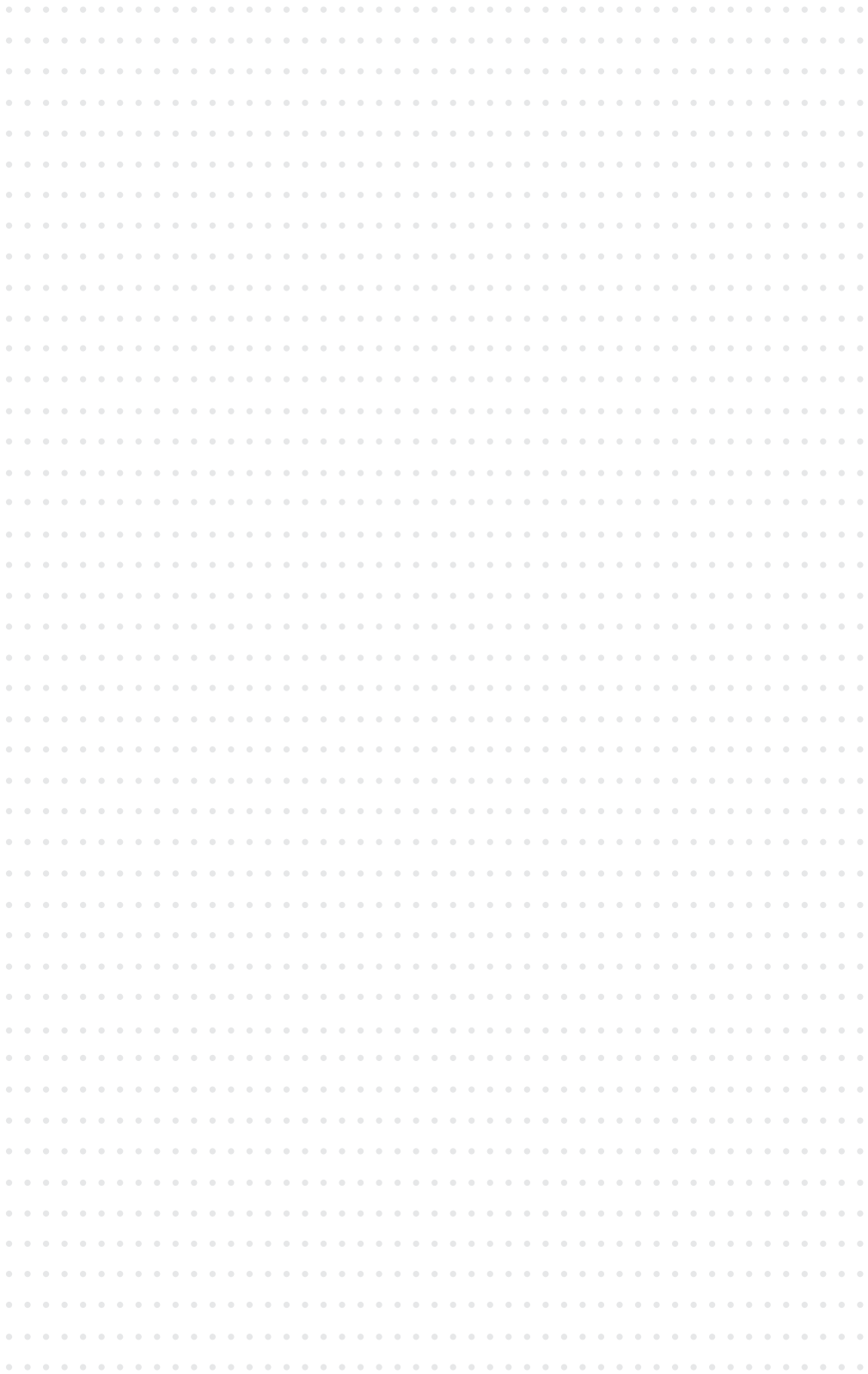



Photo credit: Viva Rio

#### Imported ammunition

**Imported ammunition of the calibers named above will have to comply with the same packaging and marking requirements as Brazilian-made ammunition.** Brazil, however, is a country that imports practically no ammunition since its legislation explicitly (and protectively) states that defense articles similar to those produced in the country are not to be imported unless there are explicit and specific national security reasons for doing so<sup>23</sup>.

Ammunition marking should not be regarded as a panacea for preventing the diversion of ammunition to criminal outfits. Combating and reducing institutional corruption, improving stockpile security and the disposal of surpluses, and reforming and adapting border control capabilities are complementary actions that must be undertaken at the same time. Technical measures can help, the key, however, is to strengthen the state so that institutions can implement such measures.

Source: Information courtesy of, and provided by, Pablo Dreyfus, Research Coordinator Small Arms Control Project, Viva Rio, Brazil.

<sup>23</sup> See Presidência da República do Brasil, 2000, Decreto No. 3665 de 20 de Novembro de 2000. Dá nova redação ao Regulamento para a Fiscalização de Produtos Controlados (R 105), Brasília, Casa Civil, Subchefia para Assuntos Jurídicos., [https://www.presidencia.gov.br/ccivil\\_03/decreto/D3665.htm](https://www.presidencia.gov.br/ccivil_03/decreto/D3665.htm), articles 183, 189, 190, 195 and 196; Presidência da República do Brasil, 2004, Decreto 5123, de 1 de Julho de 2004. Regulamenta a Lei no. 10826, de 22 de dezembro de 2003, que dispõe sobre registro, posse e comercialização de armas de fogo e munição, sobre o Sistema Nacional de Armas-Sinarm e define crimes, Brasília, Casa Civil, Subchefia de Assuntos Jurídicos. [https://www.presidencia.gov.br/ccivil\\_03/\\_Ato2004-2006/2004/Decreto/D5123.htm](https://www.presidencia.gov.br/ccivil_03/_Ato2004-2006/2004/Decreto/D5123.htm), articles 51, 52, 53 and 54.

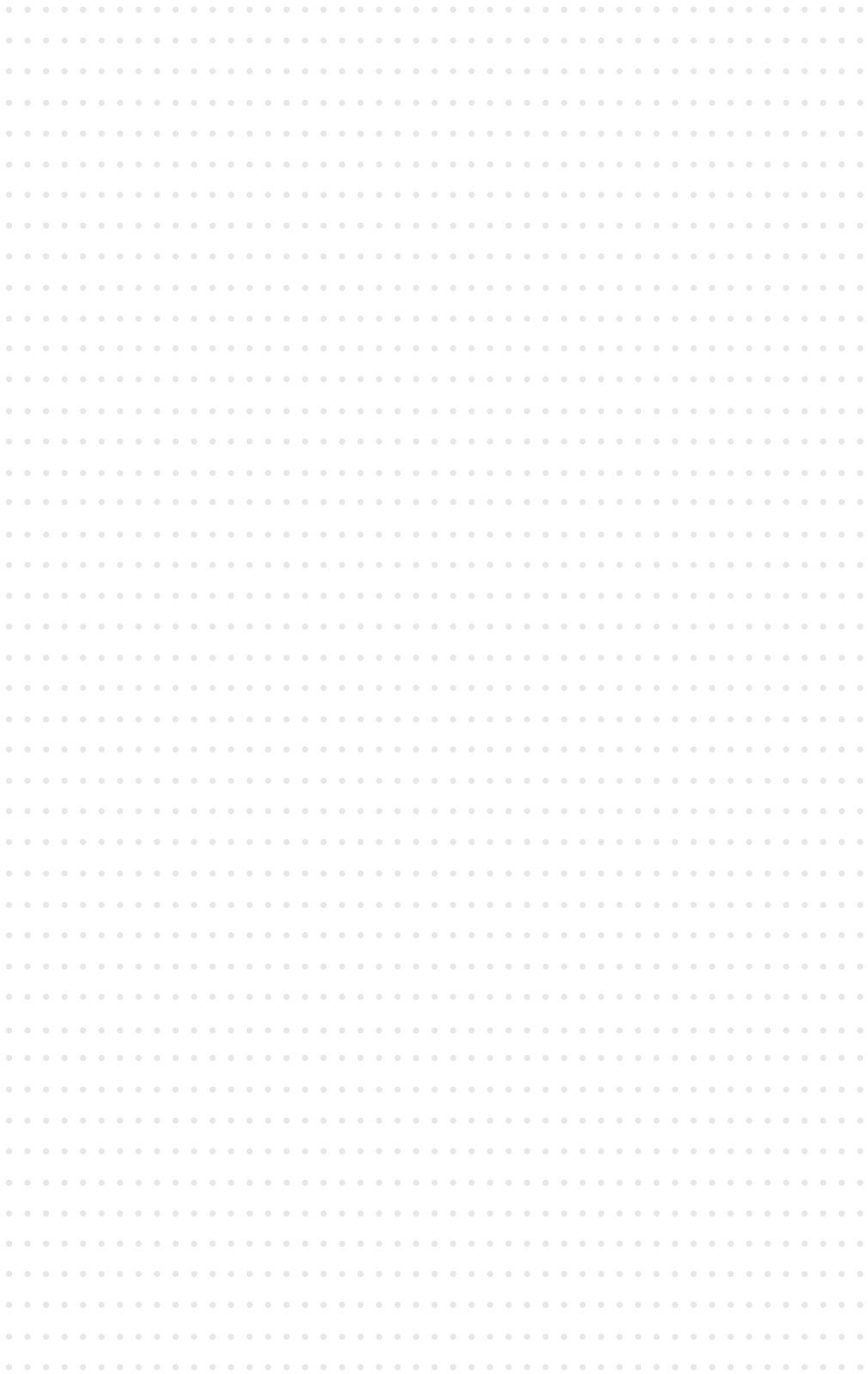

## 1.2 Marking ammunition bodies

Small arms ammunition bodies refer to the cartridge cases that hold the bullet, primer and explosive powder. They are generally marked with information engraved in a 'headstamp'.

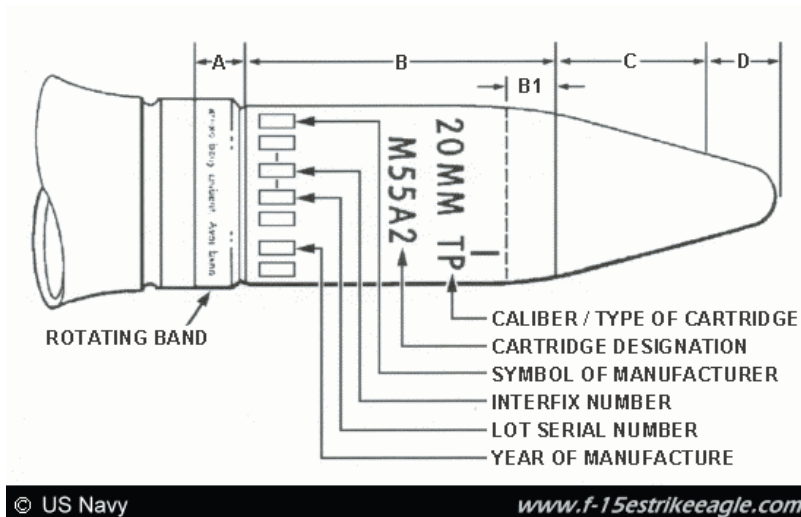

At present, the cartridge cases are typically marked with:

- Manufacturer's identity in the case of state actor markets.
- Ammunition caliber in the case of non-state actor markets.

**Note: The bodies of small arms ammunition are not usually marked with a lot #.**



This means that ammunition or empty cartridges recovered in the illicit sphere cannot be linked to a specific production run and thus to the recipient of that production run.

There are exceptions to this: for example, in Brazil, the cartridges of small arms ammunition produced for any public or legal entity is marked with a lot# (see Box 1 above).

## 1.3 Technical issues<sup>24</sup>

Traditionally, cartridges are marked in the production phase, before the case is put together with the bullet, primer and powder. The same stamp is used for each lot of approximately 500,000 rounds.

<sup>24</sup> This section is adapted from Anders, pp. 220-222

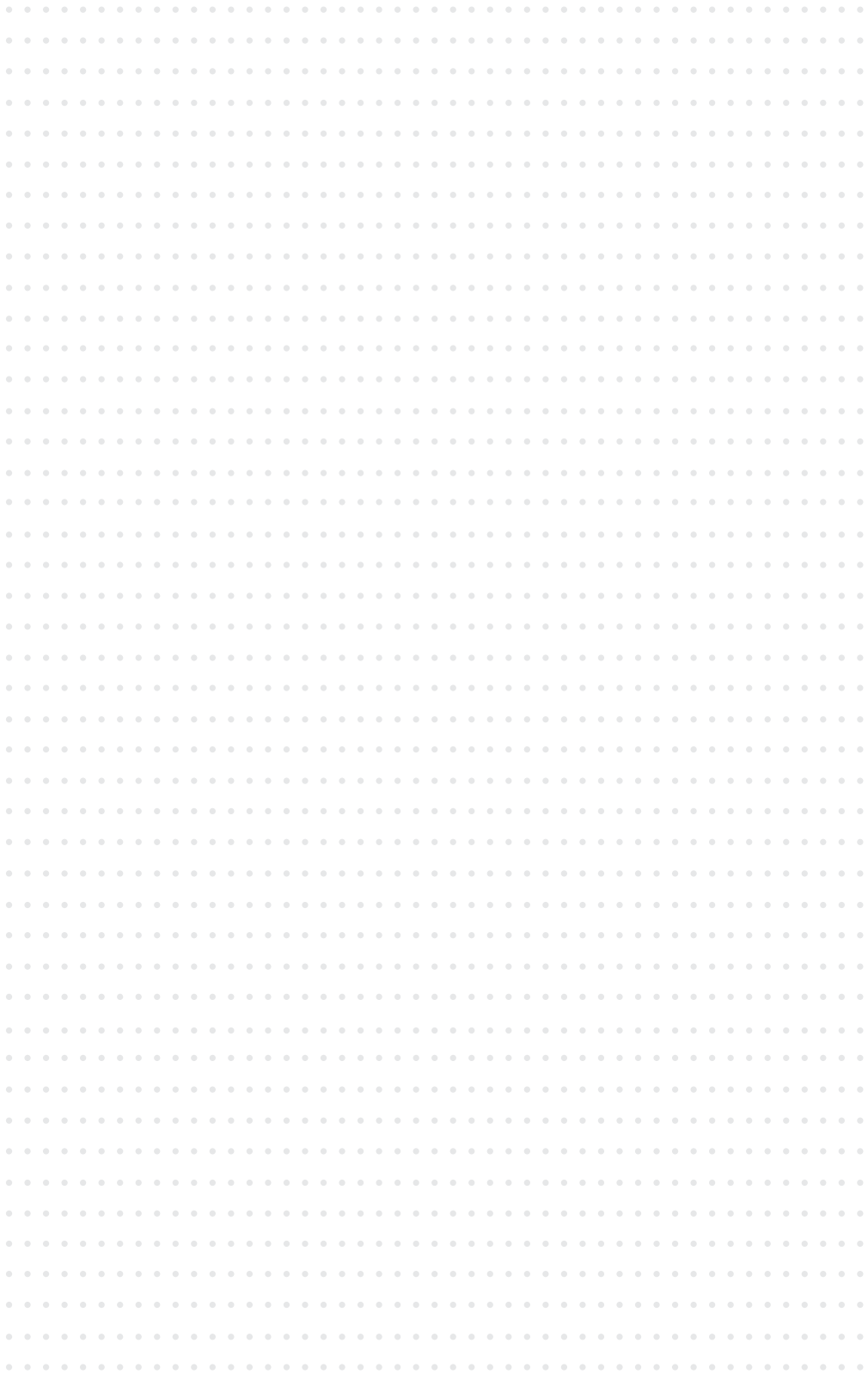

An alternative to stamping is laser marking. This is done **after** the ammunition is assembled and **before** it is packaged for transfer. A good example of this process is the Brazilian manufacturer CBC (see Box 1). CBC applies lot# markings to ammunition cartridges after they have been assembled and before the rounds are packaged for transfer. These laser markings are automatically recorded on the computer along with their initial recipient, allowing CBC to identify the state actor recipient of 10,000 rounds or less. At the same time, CBC maintains that this process:

- Does not slow down production;
- Does not pose any danger or risk of explosion;
- Does not increase production costs.

With laser technology, cartridge cases can still be pre-produced and used in different lots, as the markings applied after this process will still link them to a single recipient.

## 2. Record-keeping of small arms ammunition

Similar to tracing SALW, small arms ammunition can only be traced if the markings are properly and adequately recorded. Here there is a clear distinction in practice between ammunition produced for **state actors** (i.e. police, national army, other legal bodies) and small arms ammunition produced for **non-state actors** (i.e. sport shooters, hunters).

Small arms ammunition for **state actors** is usually produced under contract. Modern ammunition manufacturers usually keep electronic records that allow reliable identification of these recipients.

By contrast, small arms ammunition intended for **non-state actor markets** is produced according to perceived market demand. Relatively speaking, end-users in the non-state actor market only need a small amount of ammunition at a time and thus do not purchase by contract.

In practice, this means that ammunition from a particular lot will be sold to **various end-users in various non-state actor markets** (see Figure 1 below). Manufacturers of small arms ammunition are not necessarily keeping adequate records that would allow us to identify all the individual purchasers of ammunition from this lot#. Without more stringent standards, record-keeping is further compromised as the ammunition moves down the transfer chain.





Figure 1: Recipients of ammunition lots

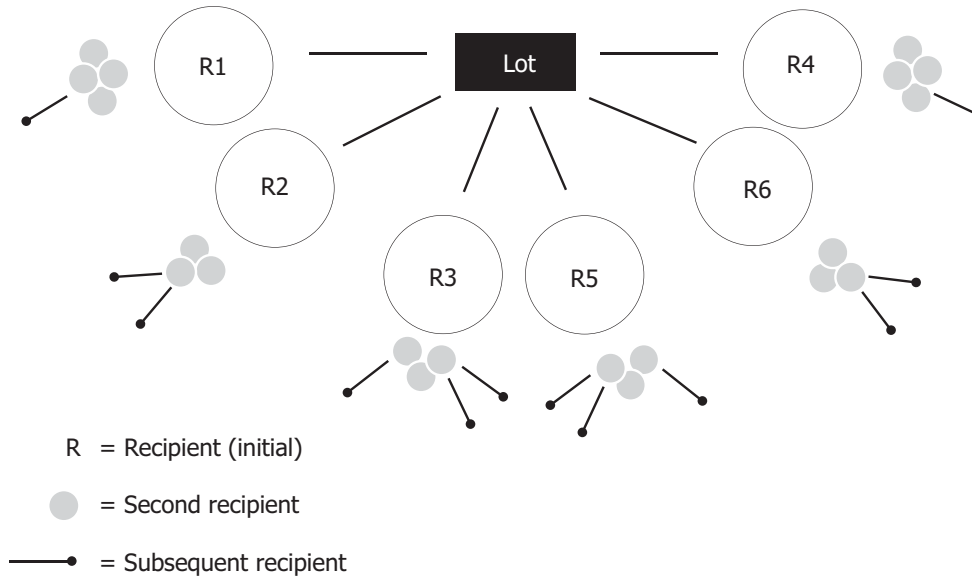

### 3. Tracing small arms ammunition

As previously noted, **tracing is a function of good marking and record-keeping practices.**

Based on current practice, small arms ammunition tracing is severely limited by:

- No lot# marking on the ammunition cartridge. While this may be included on the packaging, such packaging is often removed or discarded. Markings on small arms cartridges may still allow identification of the manufacturer, but the ammunition cannot be linked in any reliable way to a production run and to the recipient of ammunition from that production run.
- Inadequate records linking lots to specific transfer and recipients. In cases where lots are marked on small arms cartridges, these may not be recorded as the ammunition moves down the transaction chain.
- Multiple recipients of identically marked ammunition. This is particularly the case for ammunition produced for non-state actor markets, where a number of end-users receive ammunition from the same lot#, thereby bearing identical

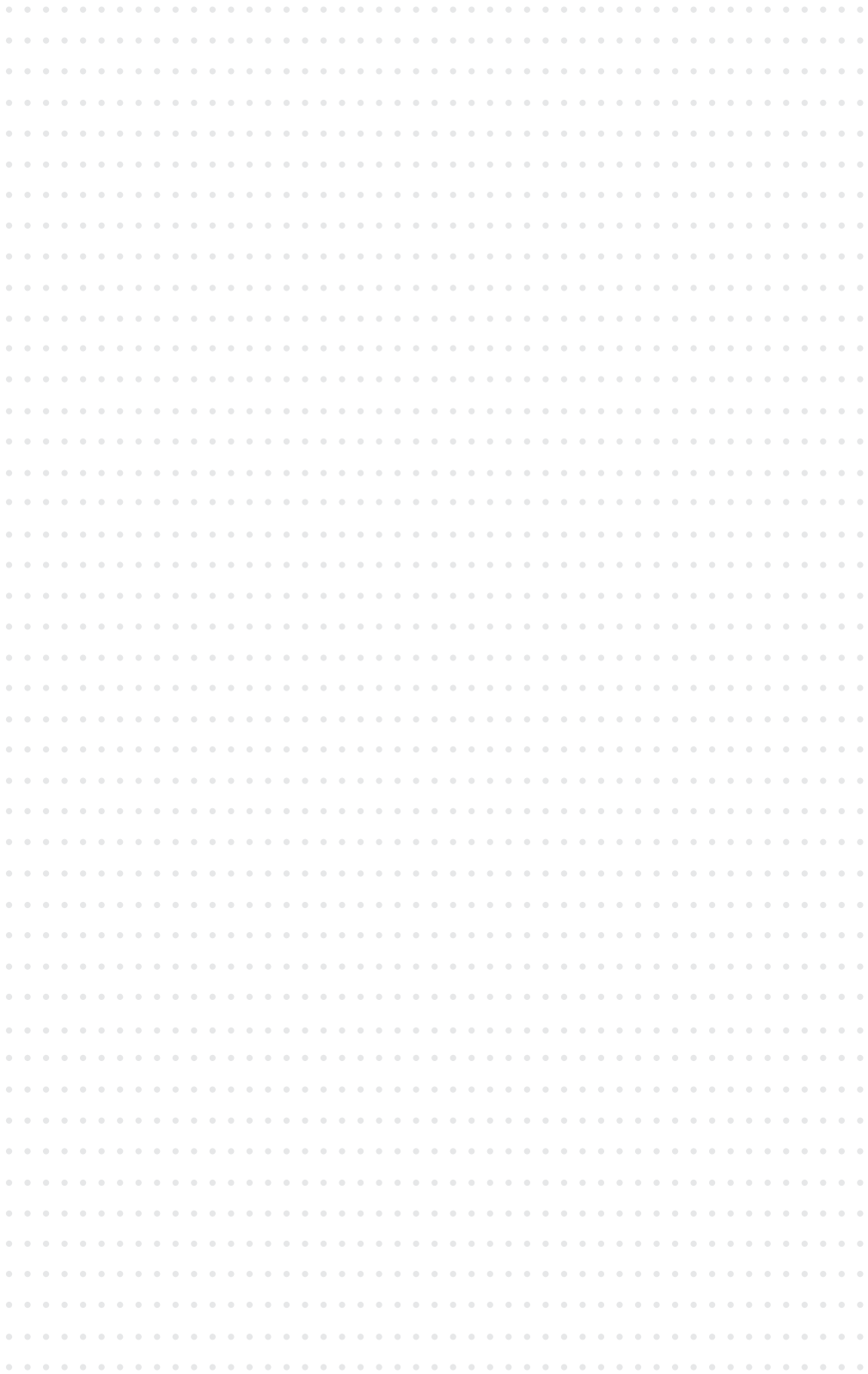

markings. If ammunition from this lot# is recovered in the illicit sphere, there is no reliable way to know, who of these end-users was the recipient of that particular ammunition.

### Box 2: Ammunition tracing applied to East Africa

Ammunition stocks can reveal important dynamics within the illicit arms market. Because ammunition is a consumable good it is traded more frequently than weapons. Due to rapid consumption, the ammunition supply chain is also statistically shorter than for small arms and light weapons. For these reasons, the Small Arms Survey has begun to test and refine a number of ammunition tracing methodologies.

Using the data from ammunition headstamps, researchers have compiled 'ammunition profiles' of a number of state and non-state armed groups in Kenya, Sudan and Uganda. Each ammunition profile is created by plotting single rounds of ammunition on a graph by their date of manufacture, their origin—factory or country—and the frequency with which rounds of a particular date and origin appear in a group's stocks (Figure 1).

Once a profile has been created for a given group of actors, researchers look for similarities or differences between groups, which might suggest the presence or absence of trade and transfer between groups. The approach relies on the statistical improbability that two groups' profiles should match each other perfectly, given the plethora of ammunition manufacturers and potential dates of manufacture. Conversely, similar features in ammunition profiles, such as for the two groups illustrated in Figure 1, point towards potential avenues of illicit trade or exchange.

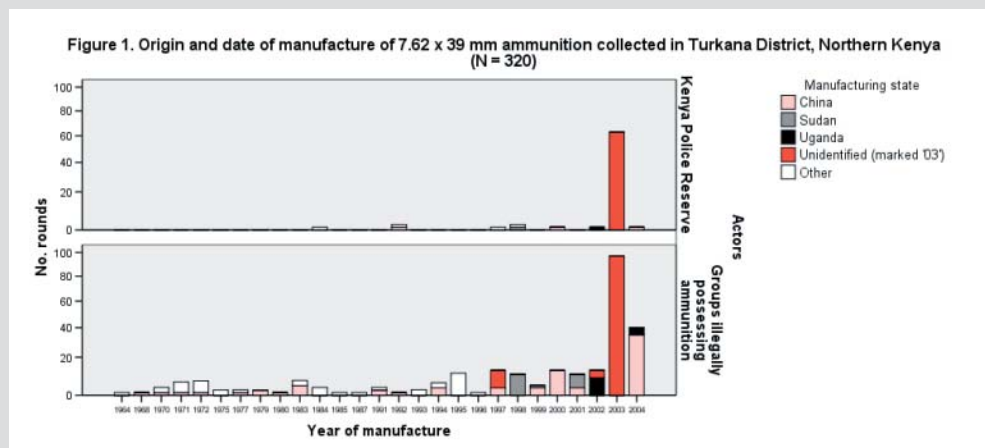

The Kenya Police Reserve (KPR) is a community defense force that is supplied with ammunition by Kenyan security forces. Figure 1 illustrates that a single type of 7.62 x 39 mm ammunition, which is stamped only with the date mark '03', comprises most of the KPR stocks in the sample. Although the ammunition is not marked with a manufacturer's code, given that it comprises 87% of KPR stocks, it is likely that this is the type of ammunition issued to Kenyan security forces—and hence to KPR by those forces.

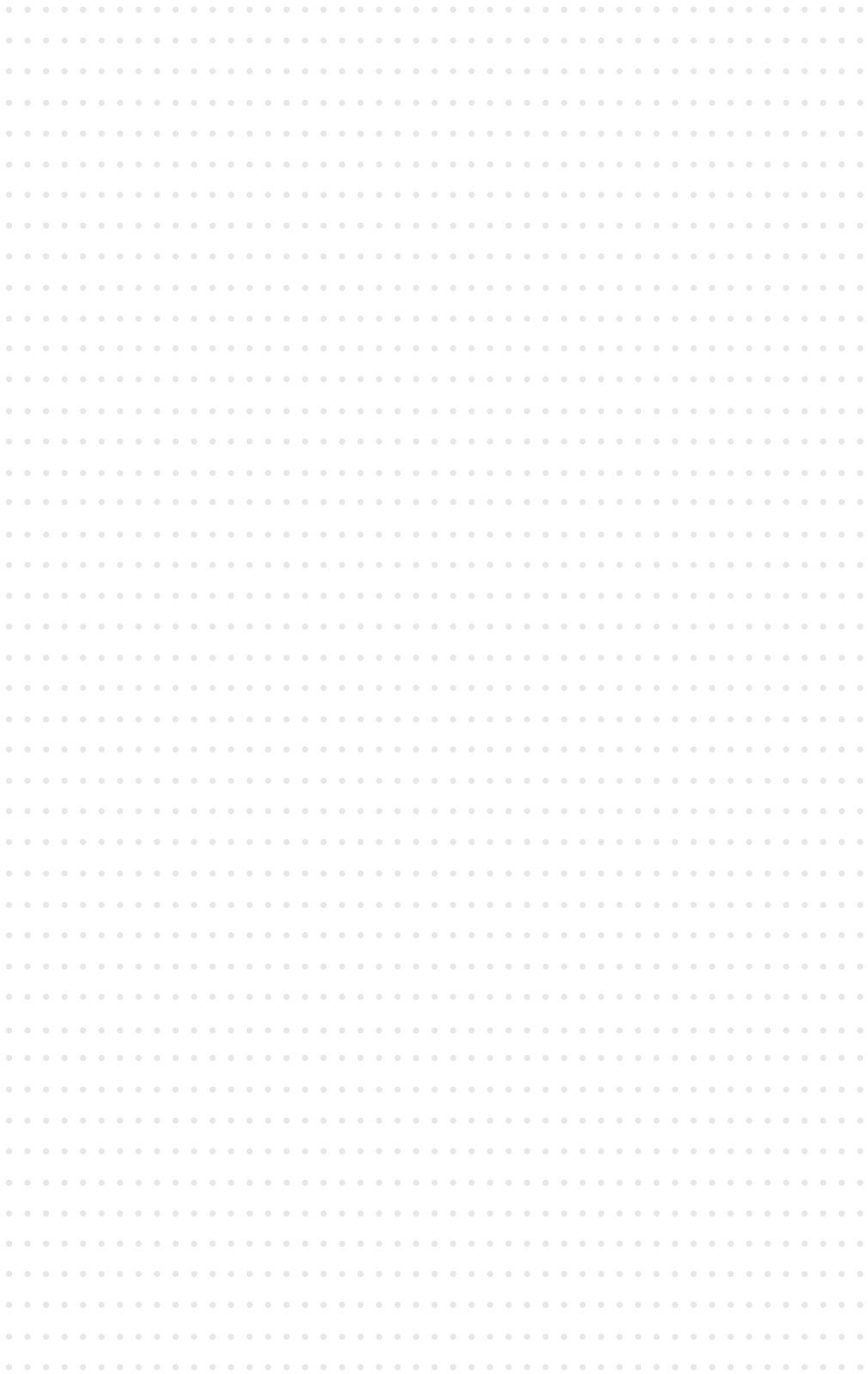

However, this ammunition is also very prevalent (41%) in the profile of a number of groups that possess ammunition illegally (Figure 1). Given that this ammunition is more densely concentrated on the illicit market in northern Kenya—and becomes less frequent or absent from samples taken at increasing distances from northern Kenya<sup>25</sup>—its source is likely to be a party in Northern Kenya.

With a number of caveats, including the need for metallurgical sampling and for specific information from the Kenyan government about the types and origins of ammunition used by the armed forces, this analysis suggests that Kenyan security force ammunition has been diverted into the illicit market.

Source: Information courtesy of, and provided by, James Bevan, Researcher, Small Arms Survey

### **Exercise 2:**

A box of 7.62 calibre NATO ammunition from a lot manufactured in 1960 has been recovered. It has been determined that this ammunition is not explosive and that it is obsolete in Germany. Without making inquiries by internet or telephone or any other forms of communication, how would you be able to check these facts?



## 4. Recommendations

- **Marking and record-keeping by production lot.** This would enhance traceability of small arms ammunition. Recipients should be required to maintain information on all further re-transfers of the same ammunition, which would hold them accountable for unauthorized re-transfers or poor standards.
- **Obligatory markings on every package of small arms ammunition** with marks that include:
  - The same information as on the individual cartridges.
  - The exact type of ammunition enclosed.
  - An identifier that is unique to that particular package.

Relevant standards here already exist, with Brazil's legislation stipulating that all ammunition be "placed in packages containing a bar code engraved on the box, in order to enable the identification of the manufacturer and purchaser"(see Box 1 above).

- **Marking small arms cartridges.** Marks should include:
  - Lot#.
  - Manufacturer and country of manufacture, if necessary.
  - Year of manufacture.
  - Code identifying original recipient of the lot (i.e. police or military force) to help identify the supply chain of the ammunition.

<sup>25</sup> The Small Arms Survey sampled extensively among groups within Turkana District, Northern Kenya and at increasing distances from the District, extending into Northern Uganda and Southern Sudan.

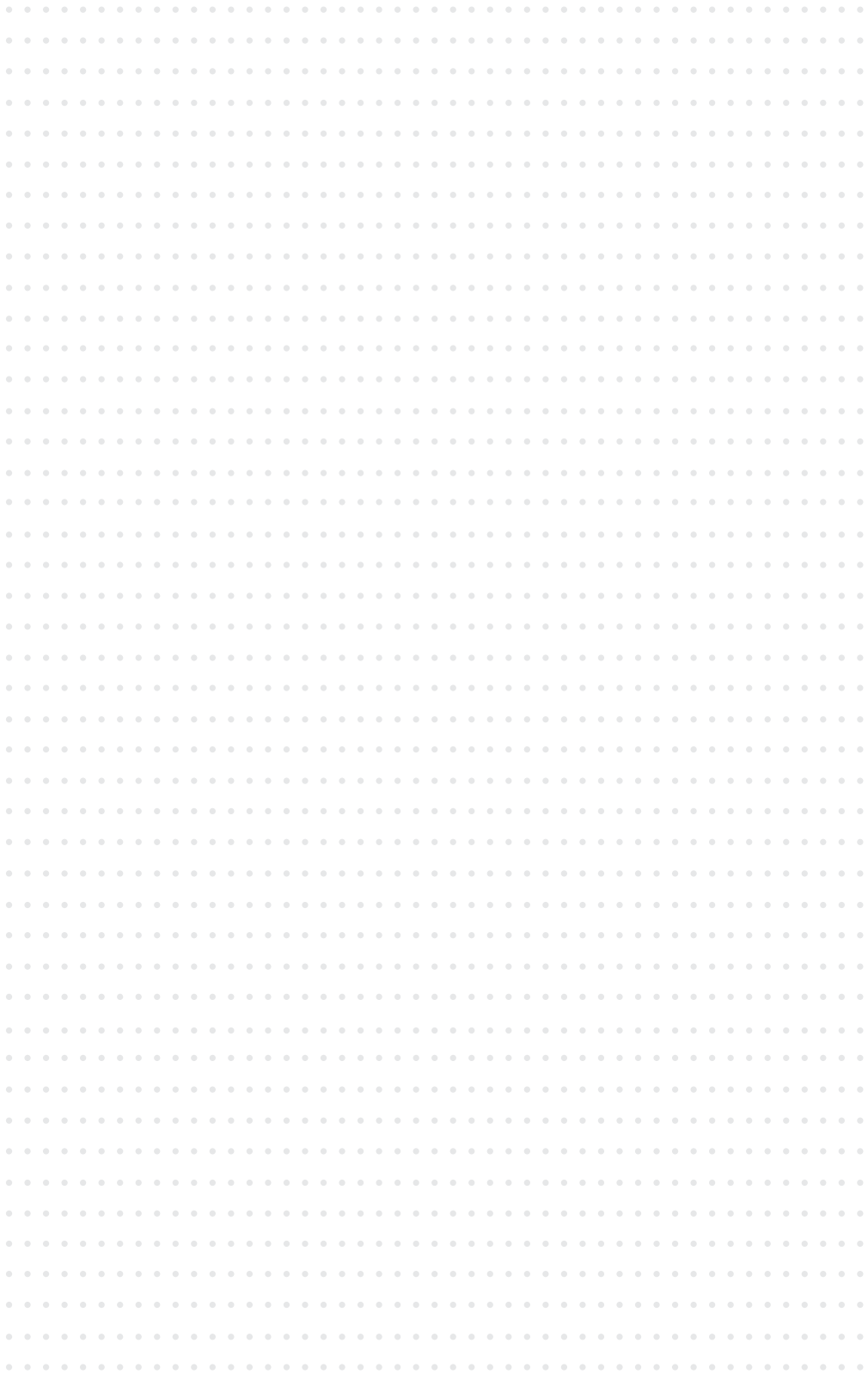

## Section 5 The way forward: Recommendations to implement the UN M&TI at the national level

### Objectives of Section 5:

By the end of this section, each trainee should have:

- A good understanding of how to implement the UN M&TI at the national level.

### 1. Introduction

The UN M&TI makes a vital contribution to combating the proliferation of illicit SALW and their misuse, and can also significantly strengthen international capacity to control the illicit transfers of SALW. Though only political in nature, the UN M&TI nevertheless contains firm commitments, which all UN Members States are urged to implement accordingly and responsibly:

- As stipulated in paragraph 24 (see Box 1 above), the first step in implementing the M&TI at the national level is for the respective governments to determine whether national laws, administrative procedures and practices are in conformity with the instrument's requirements, and if they are not, to adapt these. This is the first crucial step for the responsible implementation of the instrument.
- As part of this legislative review, States could consider strengthening national capacity for instrument implementation (e.g. inter-ministerial coordination; consultation with industry, NGOs and other stakeholders; training programs)<sup>26</sup>.
- Often national procedures differ when it comes to marking, record-keeping and tracing, and we strongly recommend governments to implement the minimum standards firmly recommended by the UN M&TI to harmonize national approaches and form an integral part of broader efforts to combat the proliferation and misuse of weapons.
- The adherence to existing regional and international agreements, comprehensive marking followed by record-keeping of nationally produced and stored SALW (ideally also imported SALW), and verification systems would mainly act as a deterrent for corrupt suppliers and/or officials who channel arms illicitly to unauthorized destinations and recipients. These measures are however not sufficient on their own, and should ideally be supplemented by an increased cooperation between states (see Box 2), as SALW are mobile commodities that are trafficked and moved across borders.

<sup>26</sup> The International Tracing Instrument: Challenges and Opportunities, PrepCom side event, 2006 Small Arms Review Conference, by Glenn McDonald, Small Arms Survey, UN New York, 13 January 2006, p.5

A large grid of dots for taking notes, consisting of 30 rows and 60 columns of small, light gray dots.





**Box 1: UN M&TI, Excerpt from Section VI, Implementation (paragraphs 24-38)**

**General**

24. In accordance with their constitutional processes, States will put in place, where they do not exist, the laws, regulations and administrative procedures needed to ensure the effective implementation of this instrument.

25. States will designate one or more national points of contact to exchange information and act as a liaison on all matters relating to the implementation of this instrument.

26. States will cooperate on a bilateral and, where appropriate, on a regional and international basis to support the effective implementation of this instrument.

**International cooperation and assistance**

...

29. States will encourage initiatives, within the framework of the United Nations Programme of Action to Prevent, Combat and Eradicate the Illicit Trade in Small Arms and Light Weapons in All Its Aspects, that mobilize the resources and expertise of, and where appropriate cooperation with, relevant regional and international organizations to promote the implementation of this instrument by States.

**United Nations**

30. States will cooperate, as appropriate, with the United Nations to support the effective implementation of this instrument.

31. States will, as soon as possible after the adoption of this instrument, provide the Secretary-General ... with the following information ... :

- (a) Name and contact information for the national point(s) of contact;
- (b) National marking practices related to markings used to indicate country of manufacture and/or country of import as applicable.

...

**VII. Follow-up**

36. States will report on a biennial basis to the Secretary-General on their implementation of this instrument...

37. States will meet on a biennial basis ... within the framework of relevant meetings convened for the United Nations Programme of Action to Prevent, Combat and Eradicate the Illicit Trade in Small Arms and Light Weapons in All Its Aspects...

38. States will review the implementation and future development of this instrument within the framework of conferences that review the United Nations Programme of Action to Prevent, Combat and Eradicate the Illicit Trade in Small Arms and Light Weapons in All Its Aspects.

Source: International Instrument to Enable States to Identify and Trace, in a Timely and Reliable Manner, Illicit Small Arms and Light Weapons (UN M&TI), pp. 5-7, [http://www.un.org/events/smallarms2006/pdf/international\\_instrument.pdf](http://www.un.org/events/smallarms2006/pdf/international_instrument.pdf)

A large grid of small dots for taking notes, consisting of 30 rows and 50 columns.

## 2. Marking SALW

**As regards marking SALW**, governments could make vital contributions to the implementation and success of the instrument (UN M&TI, Section III, paragraph 8) at the national level, by:

- Making it obligatory (for example by passing a new law or decree—see Boxes 2 and 3) that all newly manufactured SALW receive a mark that contains the country of manufacture and the weapon's unique identifier, its serial number, as minimum requirements.
- Regulating that the marking is clearly visible, of a permanent nature and found on those components of the weapon where attempts to remove it would make the weapon inoperable.
- Ensuring that all unmarked SALW already stockpiled and under a state's jurisdiction must either be appropriately marked and registered, or destroyed.
- Regulating that already manufactured or imported SALW will also receive a marking to identify the recipient, such as the State's armed forces or police force.<sup>27</sup>
- Marking all SALW at the time of import. An import mark allows for the "renewal"/ "refreshing" of the weapons trail/record-keeping chain, especially in the case of older weapons or those that have circulated among several countries.

## 3. SALW record-keeping

As regards **SALW record-keeping**, governments could make vital contributions to the timely and reliable tracing of weapons, and thereby the implementation and success of the instrument (UN M&TI, Section IV, paragraphs 11–12) at the national level, by:

- Ensuring that record-keeping systems are in place (either manually, or as a database) and include information that allows:
  - The tracing to the last owner or entity, such as the police or armed forces, in legal possession of the weapon.
  - In case of transfers, of those involved in the transport, the authorized recipient, and, where applicable, on end-use undertakings.
- Ensuring the centralization of weapons registers at the national level, or, at a minimum measure, ensuring that weapons data is accessible to all other relevant actors that may need to access this data.
- Ensuring that records are maintained and updated on a regular basis.
- Ensuring that, due to the long life span of SALW, records on each weapon entering and/or leaving a State's jurisdiction be kept until this State destroys the weapon or receives notification by another of the destruction of this weapon.<sup>28</sup> Therefore, making it obligatory to keep records of SALW for a minimum of 30 years or preferably, indefinitely.

<sup>27</sup> TRACING ILLICIT SMALL ARMS. Opportunities for the first substantive session of the Open-Ended Working Group on Tracing Illicit Small Arms and Light Weapons, IANSA, DRAFT – MAY 2004, P.4, [HTTP://WWW.IANSA.ORG/ISSUES/DOCUMENTS/IANSA\\_POSITION\\_PAPER\\_ON\\_TRACING.DOC](http://www.iansa.org/issues/documents/iansa_position_paper_on_tracing.doc)

<sup>28</sup> TRACING ILLICIT SMALL ARMS. Opportunities for the first substantive session of the Open-Ended Working Group on Tracing Illicit Small Arms and Light Weapons, IANSA, DRAFT – MAY 2004, P.4, [HTTP://WWW.IANSA.ORG/ISSUES/DOCUMENTS/IANSA\\_POSITION\\_PAPER\\_ON\\_TRACING.DOC](http://www.iansa.org/issues/documents/iansa_position_paper_on_tracing.doc)

A large grid of dots for taking notes, consisting of 30 rows and 50 columns of small, light gray dots.

**Note:** The costs to maintain these records for an indefinite time are not high; especially if maintained electronically.



#### 4. Tracing SALW

As regards **tracing SALW**, governments could make vital contributions to the implementation and success of the instrument (UN M&TI, Section V, paragraphs 14–23) at the national level, by:

- Ensuring international cooperation in tracing.
- Taking into account the differences between requirements for tracing illicit SALW that are recovered in crime and those recovered in armed conflict. SALW recovered in armed conflict tend to have more complex trade paths and Interpol may have limitations in practice to trace weapons recovered in conflict or post-conflict situations.<sup>29</sup> Hence, it is necessary to find complementary approaches.
- Requesting assistance or providing such technical assistance to states for the establishment of national tracing infrastructures.<sup>30</sup> Such assistance can be provided in the form of, for example, equipment and training for the use of laser marking and engraving machines for post-production markings, as well as for the introduction of adequate record-keeping systems within, for example, the State security forces.

**Figure 1:** Practical aspects of tracing SALW and the duties of a state to collaborate and implement the Instrument. What are the formal processes? How can networks to trace SALW be created?

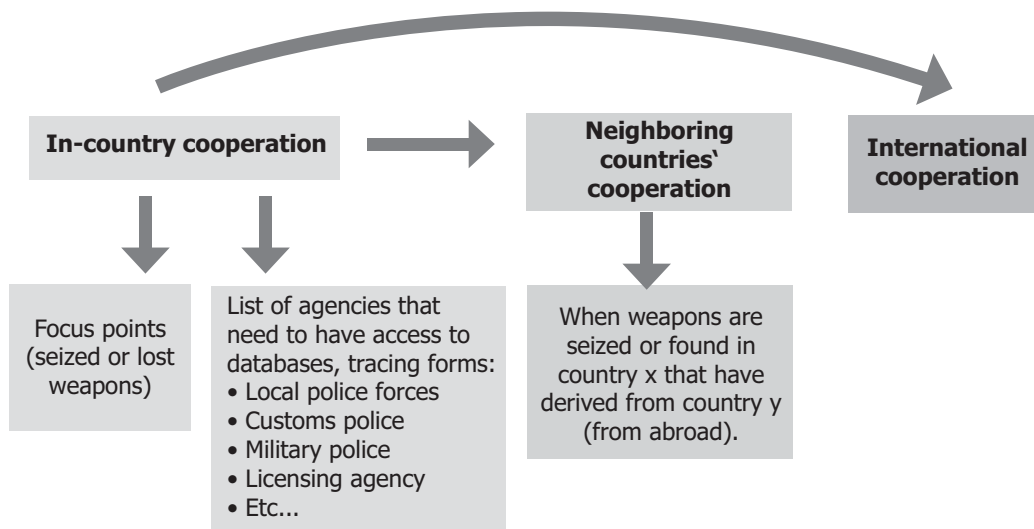

<sup>29</sup> TRACING ILLICIT SMALL ARMS. Opportunities for the first substantive session of the Open-Ended Working Group on Tracing Illicit Small Arms and Light Weapons, IANSA, DRAFT – MAY 2004, P.6, [HTTP://WWW.IANSA.ORG/ISSUES/DOCUMENTS/IANSA\\_POSITION\\_PAPER\\_ON\\_TRACING.DOC](http://www.iansa.org/issues/documents/iansa_position_paper_on_tracing.doc)

<sup>30</sup> TRACING ILLICIT SMALL ARMS. Opportunities for the first substantive session of the Open-Ended Working Group on Tracing Illicit Small Arms and Light Weapons, IANSA, DRAFT – MAY 2004, P.6, [HTTP://WWW.IANSA.ORG/ISSUES/DOCUMENTS/IANSA\\_POSITION\\_PAPER\\_ON\\_TRACING.DOC](http://www.iansa.org/issues/documents/iansa_position_paper_on_tracing.doc)

A large grid of dots for taking notes, consisting of 30 rows and 60 columns of small, light gray dots.

## 5. Addressing ammunition

The issue of ammunition was a controversial one during the negotiation of the M&TI. While a number of States supported the inclusion of high common standards on marking and tracing small arms ammunition, opposition from others led to its exclusion from the UN document. Instead, the issue of ammunition is to be addressed as a separate process within the framework of the UN<sup>31</sup>.

In addition to the above-mentioned recommendations, we strongly urge consideration of the following measures that would complement and enhance the implementation of the UN M&TI.

## 6. Complementary measures

The recommended measures of the UN M&TI are only one way to avoid the diversion of illicit SALW. Other measures that complement the instrument's recommendations (UN M&TI, Section V, paragraphs 14–23) and that are of a truly preventative nature include:

### ■ International Assistance

International assistance is a crucial element to the effective implementation of the UN M&TI. According to McDonald, during the negotiations, some States would not agree to the mandatory marking of SALW at the time of import because of concern about potential costs. This is one area where international assistance could prove especially useful. Furthermore, international assistance will also be needed to help countries fulfil their other marking commitments and to build national capacity for effective record-keeping and tracing<sup>32</sup>.

### ■ Safeguarding and inspecting arms holdings and deliveries

The lack of common international standards for the safe storage of arms holdings and arms in transit permits theft and the diversion of arms during their transfer, including by original recipients. Governments should ensure high common standards for the operational effectiveness of verification arrangements to check the security of arms in holdings and stockpiles, and to verify the delivery of legitimate arms transfers.<sup>33</sup>

### ■ Information sharing<sup>34</sup>

States should exchange among themselves, in conformity with their respective domestic laws and applicable treaties, relevant information on matters such as:

<sup>31</sup> This is according to the recommendation of the Open-Ended Working Group on Tracing Illicit Small Arms and Light Weapons (OEWG report, paragraph 27) that negotiated the M&TI.

<sup>32</sup> The International Tracing Instrument: Challenges and Opportunities, PrepCom side event, 2006 Small Arms Review Conference, by Glenn McDonald, Small Arms Survey, UN New York, 13 January 2006, p.6

<sup>33</sup> Tracking Lethal Tools. Marking and Tracing Arms and Ammunition: a central piece of the arms control puzzle, by Amnesty International, Oxfam, and IANSA (International Action Network on Small Arms), for the Control Arms Campaign, pp.15-16, [http://www.oxfam.org.uk/what\\_we\\_do/issues/conflict\\_disasters/downloads/tracking\\_lethal\\_tools.pdf](http://www.oxfam.org.uk/what_we_do/issues/conflict_disasters/downloads/tracking_lethal_tools.pdf)

<sup>34</sup> Source: OSCE Best Practice Guide on Marking, Record-keeping and Traceability of Small Arms and Light Weapons, p.11, [http://www.osce.org/publications/fsc/2003/12/13550\\_31\\_en.pdf](http://www.osce.org/publications/fsc/2003/12/13550_31_en.pdf)

A large grid of dots for taking notes, consisting of 30 rows and 50 columns of small, light gray dots.



- i) Authorized producers, dealers, importers, exporters, and, whenever possible, carriers of SALW.
- ii) The means of concealment used in the illicit manufacturing of or trafficking in SALW, and methods to detect them.
- iii) Routes customarily used by organizations engaged in illicit trafficking in SALW.
- iv) Legislative experiences, practices, and measures to prevent, combat, and eradicate the illicit manufacturing of and trafficking in SALW.

■ Promoting stockpile and transfer security

In particular, states need to agree on effective measures to ensure the security of SALW in stockpiles and during transfer to avoid the theft or diversion of these weapons (and ammunition). Governments must strengthen national physical verification at points of storage, loading, transfer, and unloading. Regular cross-checks must be carried out to verify that recorded information corresponds to the actual serial numbers, types and quantities in the arms shipment or stockpile.

Governments should provide practical manuals containing the highest standards and best practices for the identification and tracing of illicit weapons to the responsible authorities including police, customs, border guards, the military and the judiciary. Such personnel must also have adequate training, communication systems and equipment to monitor and control transfers and stockpiles of weapons. States in a position to do so should offer technical and financial assistance to support the establishment of adequate marking technologies, record-keeping systems, secure stockpile management, training and verification tasks in other countries.<sup>35</sup>

**Note:** With a number of issues relating to marking and tracing and their implementation, the OSCE Best Practice Guide goes into more detail than the UN M&TI. We therefore recommend you to consider this guide as a complementary document to the UN M&TI.



## Box 2: Cooperation—OSCE Best Practice

States should cooperate at the bilateral, regional, and international levels to prevent, combat, and eradicate the illicit manufacturing of and trafficking in SALW. States should further identify a national body or a single point of contact to act as a liaison among States for the purposes of cooperation in information exchange and SALW tracing.

Unless otherwise agreed, information received during a tracing operation should be deemed confidential. The requested State should be empowered to restrict the use of the information it provides. The nature and scope of that restriction should not prevent the requesting State from continuing the tracing operation through other means.

<sup>35</sup> Tracking Lethal Tools. Marking and Tracing Arms and Ammunition: a central piece of the arms control puzzle, by Amnesty International, Oxfam, and IANSA (International Action Network on Small Arms), for the Control Arms Campaign, p.16, [http://www.oxfam.org.uk/what\\_we\\_do/issues/conflict\\_disasters/downloads/tracking\\_lethal\\_tools.pdf](http://www.oxfam.org.uk/what_we_do/issues/conflict_disasters/downloads/tracking_lethal_tools.pdf)

A large grid of dots for taking notes, consisting of 30 rows and 60 columns of small, light gray dots.

The State requesting cooperation from another State should support its request with all relevant information, such as:

- The type and quantity of the weapons concerned, and the date and place of their confiscation, seizure, collection or recovery.
- Markings and any further information that may help identify them.
- Any further available information to help identify the weapons or ammunition concerned (descriptions, photographs, etc.).
- Any further relevant information, such as where the weapons were found, identities of persons detained with the confiscated weapons, etc.

The State that receives the request for cooperation should undertake to acknowledge receipt thereof, and to provide any information it possesses to the requesting State, as rapidly as possible (a week could be considered as a reference). Such information might include:

- i) Confirmation that the weapons concerned were manufactured in the State from which information has been requested, if this is shown by the marking.
- ii) Any further information on the weapons concerned that is likely to ensure reliable identification, such as, for example: the date of manufacture; relevant information on the manufacturer; hidden or other identification markings; special characteristics; and the date on which technical testing was conducted, and identification of the testing body, and so on.
- iii) If the weapons concerned have been transferred legally out of the requested State, the date of export; the importing State and transit States where relevant; the final consignee, and any additional information to assist the requesting State in tracing the weapons.
- iv) If the weapons concerned have not been transferred legally out of the requested State, confirmation of that fact and communication of any additional information to assist the requesting State in tracing the weapons. The requested State shall also specify whether an investigation has been launched on the apparent loss, theft or diversion of the weapons concerned.

Source: OSCE Best Practice Guide on Marking, Record-keeping and Traceability of Small Arms and Light Weapons, p.12, [http://www.osce.org/publications/fsc/2003/12/13550\\_31\\_en.pdf](http://www.osce.org/publications/fsc/2003/12/13550_31_en.pdf)

A large area of the page is filled with a grid of small, light gray dots, intended for taking notes.

### Box 3: National legislation—OSCE Best Practice



National legislation concerning control over the manufacture of SALW should reflect all the existing international obligations of the State in this field. As a rule, national control over the manufacture of weapons and military equipment also extends to the manufacture of SALW.

National legislation concerning control over the manufacture of SALW should contain the following:

- i) Licensing requirements and conditions.
- ii) Licensing and authorizing bodies.
- iii) Procedures for the submission and examination of applications for licenses and authorizations.
- iv) Licensing and authorization procedures.
- v) Suspension, review, renewal and revocation of licenses and authorizations.
- vi) Enforcement of licensing requirements.
- vii) Penalties (e.g. criminal liability for unlicensed manufacturing).

National legislation on the control over the manufacture of SALW should include political guidelines regulating this activity without prejudice to the rights, legitimate interests and health of citizens, or the defense and security of the State.

Source: OSCE Best Practice Guide on National Controls over Manufacture of Small Arms and Light Weapons, p.4, [http://www.osce.org/publications/fsc/2003/12/13550\\_30\\_en.pdf](http://www.osce.org/publications/fsc/2003/12/13550_30_en.pdf)

#### **Control at the manufacturing stage**

The manufacture of SALW should be monitored by both the manufacturer and the recipient, on the basis of instructions or guidelines specified in the national legislation.

#### **1. Control by the recipient**

SALW manufacture should be ordered by bodies authorized by national governments. At a minimum, a contract for the manufacture of SALW should contain the following information:

- i) Type of weapons.
- ii) Number of pieces.
- iii) Period of manufacture.

The specifications of the manufactured SALW should be listed in the technical documentation. The required materials to be used to manufacture the weapons and

A large grid of dots for taking notes, consisting of 30 rows and 60 columns of small, light gray dots.

the basic combat characteristics of the weapons should be specified when each model is developed. The manufacturer must ensure that the finished product complies with the required specifications.

The recipient may control the quality of the finished product at the manufacturer's premises through its representatives, who will carry out control checks of the manufacturing quality at both the production and assembly stages. If the finished product is transported by the recipient, the serial numbers and completeness of all SALW should be verified, recorded and maintained in accordance with national law.

Where applicable, the manufacturer should provide decommissioning (destruction) certificates for the components manufactured at other enterprises.

## **2. Control by the manufacturer**

At the stage of SALW manufacture, controls could cover:

- i) Use of technical (design and technological) weapons documentation.
- ii) Use of special equipment required to manufacture the weapons.
- iii) Parts, assemblies and finished weapons.
- iv) Substandard weapons and their parts, registered by serial number during manufacture or destruction.
- v) Marking and stamping of the weapons.

During the manufacture of SALW, records (log books) should be kept to indicate the number and type of firearms manufacture, including serial numbers and other appropriate information necessary to trace the firearm.

## **3. Control over SALW components**

Major components for the manufacture of SALW (e.g. firearms' frames and receivers) should be controlled and appropriately marked upon manufacture. Manufacturers should ensure that assembly and production lines permit the accurate marking and accounting of these components.

Manufacturers should establish appropriate procedures for proper storage, transportation and record-keeping of these components (see OSCE Best Practice Guide on National Procedures for Stockpile Management and Security, [http://www.osce.org/publications/fsc/2003/12/13550\\_32\\_en.pdf](http://www.osce.org/publications/fsc/2003/12/13550_32_en.pdf)).

## **4. Control over finished SALW**

After final assembly, each weapon should be assigned a full identification number. The corresponding documentation should be completed and handed over to the recipient, together with the finished products (see OSCE Best Practice Guide on Marking, Record-keeping and Traceability of Small Arms and Light Weapons, [http://www.osce.org/publications/fsc/2003/12/13550\\_31\\_en.pdf](http://www.osce.org/publications/fsc/2003/12/13550_31_en.pdf)).

Authorization to transport major components and completed firearms should be established. Manufacturers should also ensure proper accounting and recording of the finished products, especially when the major components or finished products are to be transported.

A large grid of dots for taking notes, consisting of 30 rows and 50 columns of small, light gray dots.



The manufactured SALW to be transferred to the recipient should be kept in storage facilities, if possible on the main production site. The storage facilities should be appropriately secured to prevent unauthorized access (see OSCE Best Practice Guide on National Procedures for Stockpile Management and Security, [http://www.osce.org/publications/fsc/2003/12/13550\\_32\\_en.pdf](http://www.osce.org/publications/fsc/2003/12/13550_32_en.pdf)).

#### **5. Penalties for violations of SALW management procedures**

Appropriate civil, administrative or criminal penalties should be established for violations of State procedures for manufacturing, transferring or storing SALW.

For more information on licensing requirements and conditions, licensing and authorizing bodies, issuance of licenses and authorizations, suspension, review, renewal and revocation of licenses and authorizations, and the control over compliance with existing requirements see OSCE Best Practice Guide on National Controls over Manufacture of Small Arms and Light Weapons, [http://www.osce.org/publications/fsc/2003/12/13550\\_30\\_en.pdf](http://www.osce.org/publications/fsc/2003/12/13550_30_en.pdf).

Source: OSCE Best Practice Guide on National Controls over Manufacture of Small Arms and Light Weapons, pp.8-9, [http://www.osce.org/publications/fsc/2003/12/13550\\_30\\_en.pdf](http://www.osce.org/publications/fsc/2003/12/13550_30_en.pdf)

#### **Box 4: Legal basis and penal regime—OSCE Best Practice**



Governments that have not already done so should adopt laws and regulations on marking and record-keeping of SALW consistent with their legal systems. The provisions of concern should provide for obligations, prohibitions and punishment of offences. They should cover all aspects that would promote the concept of traceability.

Governments should consider adopting and implementing legislative and other measures consistent with their constitutional and legal systems to establish as penal offences the following intentionally committed acts:

- Manufacturing of and trade in unmarked SALW.
- Falsification, illegal removal or alteration of SALW markings that render the weapon unique.
- Failure to register SALW.
- Any form of falsification of SALW record-keeping.

Source: Adapted from: OSCE Best Practice Guide on Marking, Record-keeping and Traceability of Small Arms and Light Weapons, p.10, [http://www.osce.org/publications/fsc/2003/12/13550\\_31\\_en.pdf](http://www.osce.org/publications/fsc/2003/12/13550_31_en.pdf)

A large grid of dots for taking notes, consisting of 30 rows and 50 columns of small, light gray dots.

# Annex I: UN Instrument on Marking and Tracing

Small Arms  
REVIEW CONFERENCE  
2006



United Nations

A/CONF.192/15

## **International Instrument to Enable States to Identify and Trace, in a Timely and Reliable Manner, Illicit Small Arms and Light Weapons**

Adopted by the United Nations General Assembly on 8 December 2005

### **Preamble**

*States,*

*Noting* that in the United Nations Programme of Action to Prevent, Combat and Eradicate the Illicit Trade in Small Arms and Light Weapons in All Its Aspects,<sup>1</sup> States identified the tracing of illicit small arms and light weapons as a key mechanism for national, regional and/or international efforts to prevent, combat and eradicate illicit small arms and light weapons and committed themselves to strengthening the ability of States to cooperate in identifying and tracing in a timely and reliable manner illicit small arms and light weapons,

*Noting also* that the tracing of illicit small arms and light weapons, including but not limited to those manufactured to military specifications, may be required in the context of all forms of crime and conflict situations,

*Recalling* the report on the feasibility of developing an international instrument to enable States to identify and trace, in a timely and reliable manner, illicit small arms and light weapons,<sup>2</sup> prepared by the Group of Governmental Experts established pursuant to General Assembly resolution 56/24 V of 24 December 2001,

*Recalling also* General Assembly resolution 58/241 of 23 December 2003, in which the Assembly, pursuant to the recommendation of the Group of Governmental Experts, decided to establish an open-ended working group to negotiate such an instrument,

*Noting* that, pursuant to resolution 58/241, this instrument is complementary to, and not inconsistent with, the existing commitments of States under relevant international instruments, including the Protocol against the Illicit Manufacturing of and Trafficking in Firearms, Their Parts and Components and Ammunition, supplementing the United Nations Convention against Transnational Organized Crime,<sup>3</sup>

*Noting also* that, pursuant to resolution 58/241, this instrument takes into account the national security and legal interests of States,

<sup>1</sup> See Report of the United Nations Conference on Illicit Trade in Small Arms and Light Weapons in All Its Aspects, New York, 9-20 July 2001 (A/CONF.192/15), para. 24.

<sup>2</sup> A/58/138.

<sup>3</sup> General Assembly resolution 55/255, annex.

United Nations Conference to Review Progress Made in the Implementation of the Programme of Action to Prevent, Combat and Eradicate the Illicit Trade in Small Arms and Light Weapons in All Its Aspects  
New York, 26 June – 7 July 2006 • [www.un.org/smallarms2006](http://www.un.org/smallarms2006)

A large grid of dots for taking notes, consisting of 30 rows and 50 columns of small, light gray dots.

*Convinced* of the need for an effective international instrument to enable States to identify and trace, in a timely and reliable manner, illicit small arms and light weapons,

*Stressing* that all aspects relating to illicit small arms and light weapons should be addressed in a coordinated and comprehensive manner,

*Stressing* also the urgent necessity for international cooperation and assistance, including financial and technical assistance, as appropriate, to support and facilitate efforts to effectively implement this instrument,

*Have agreed henceforth as follows:*

#### **I. General provisions**

1. The purpose of this instrument is to enable States to identify and trace, in a timely and reliable manner, illicit small arms and light weapons.
2. The purpose of this instrument is also to promote and facilitate international cooperation and assistance in marking and tracing and to enhance the effectiveness of, and complement, existing bilateral, regional and international agreements to prevent, combat and eradicate the illicit trade in small arms and light weapons in all its aspects.
3. This instrument does not restrict the right of States to acquire, manufacture, transfer and retain small arms and light weapons for their self-defence and security needs, as well as for their capacity to participate in peacekeeping operations, in a manner consistent with the Charter of the United Nations.

#### **II. Definitions**

4. For the purposes of this instrument, “small arms and light weapons” will mean any man-portable lethal weapon that expels or launches, is designed to expel or launch, or may be readily converted to expel or launch a shot, bullet or projectile by the action of an explosive, excluding antique small arms and light weapons or their replicas. Antique small arms and light weapons and their replicas will be defined in accordance with domestic law. In no case will antique small arms and light weapons include those manufactured after 1899:
  - (a) “Small arms” are, broadly speaking, weapons designed for individual use. They include, inter alia, revolvers and self-loading pistols, rifles and carbines, sub-machine guns, assault rifles and light machine guns;
  - (b) “Light weapons” are, broadly speaking, weapons designed for use by two or three persons serving as a crew, although some may be carried and used by a single person. They include, inter alia, heavy machine guns, hand-held under-barrel and mounted grenade launchers, portable anti-aircraft guns, portable anti-tank guns, recoilless rifles, portable launchers of anti-tank missile and rocket systems, portable launchers of anti-aircraft missile systems, and mortars of a calibre of less than 100 millimetres.
5. For the purposes of this instrument, “tracing” is the systematic tracking of illicit small arms and light weapons found or seized on the territory of a State from the point of manufacture or the point of importation through the lines of supply to the point at which they became illicit.
6. For the purposes of this instrument, small arms and light weapons are “illicit” if:
  - (a) They are considered illicit under the law of the State within whose territorial jurisdiction the small arm or light weapon is found;

A large grid of dots for taking notes, consisting of 30 rows and 60 columns of small, light gray dots.

- (b) They are transferred in violation of arms embargoes decided by the Security Council in accordance with the Charter of the United Nations;
- (c) They are not marked in accordance with the provisions of this instrument;
- (d) They are manufactured or assembled without a licence or authorization from the competent authority of the State where the manufacture or assembly takes place; or
- (e) They are transferred without a licence or authorization by a competent national authority.

### **III. Marking**

7. The choice of methods for marking small arms and light weapons is a national prerogative. States will ensure that, whatever method is used, all marks required under this instrument are on an exposed surface, conspicuous without technical aids or tools, easily recognizable, readable, durable and, as far as technically possible, recoverable.
8. For the purpose of identifying and tracing illicit small arms and light weapons, States will:
  - (a) At the time of manufacture of each small arm or light weapon under their jurisdiction or control, either require unique marking providing the name of the manufacturer, the country of manufacture and the serial number, or maintain any alternative unique user-friendly marking with simple geometric symbols in combination with a numeric and/or alphanumeric code, permitting ready identification by all States of the country of manufacture; and encourage the marking of such additional information as the year of manufacture, weapon type/model and calibre;
  - (b) Taking into account that import marking is a requirement for the States parties to the Protocol against the Illicit Manufacturing of and Trafficking in Firearms, Their Parts and Components and Ammunition, supplementing the United Nations Convention against Transnational Organized Crime, require to the extent possible appropriate simple marking on each imported small arm or light weapon, permitting identification of the country of import and, where possible, the year of import and enabling the competent authorities of that country to trace the small arm or light weapon; and require a unique marking, if the small arm or light weapon does not already bear such a marking. The requirements of this subparagraph need not be applied to temporary imports of small arms and light weapons for verifiable, lawful purposes, nor for the permanent import of museum artefacts;
  - (c) Ensure, at the time of transfer from government stocks to permanent civilian use of a small arm or light weapon that is not marked in a manner that allows tracing, the appropriate marking permitting identification of the country from whose stocks the transfer of the small arm or light weapon is made;
  - (d) Take all necessary measures to ensure that all small arms and light weapons in the possession of government armed and security forces for their own use at the time of adoption of this instrument are duly marked. Markings on these small arms and light weapons do not necessarily have to meet the requirements of subparagraph 8 (a) above;
  - (e) Encourage manufacturers of small arms and light weapons to develop measures against the removal or alteration of markings.

A large grid of dotted lines for taking notes, consisting of 30 rows and 40 columns of dots.



9. States will ensure that all illicit small arms and light weapons that are found on their territory are uniquely marked and recorded, or destroyed, as soon as possible. Pending such marking, and recording in accordance with section IV of this instrument, or destruction, these small arms and light weapons will be securely stored.
10. States will ensure that every small arm or light weapon always receives the unique markings prescribed in subparagraph 8 (a) above. A unique marking should be applied to an essential or structural component of the weapon where the component's destruction would render the weapon permanently inoperable and incapable of reactivation, such as the frame and/or receiver, in compliance with paragraph 7 above. States are encouraged, where appropriate to the type of weapon, also to apply the marking prescribed in subparagraph 8 (a) above or other markings to other parts of the weapon such as the barrel and/or slide or cylinder of the weapon, in order to aid in the accurate identification of these parts or of a given weapon.

#### **IV. Record-keeping**

11. The choice of methods for record-keeping is a national prerogative. States will ensure that accurate and comprehensive records are established for all marked small arms and light weapons within their territory and maintained in accordance with paragraph 12 below in order to enable their competent national authorities to trace illicit small arms and light weapons in a timely and reliable manner.
12. From the time of the adoption of this instrument, records pertaining to marked small arms and light weapons will, to the extent possible, be kept indefinitely, but in any case a State will ensure the maintenance of:
  - (a) Manufacturing records for at least 30 years; and
  - (b) All other records, including records of import and export, for at least 20 years.
13. States will require that records pertaining to small arms and light weapons held by companies that go out of business be forwarded to the State in accordance with its national legislation.

#### **V. Cooperation in tracing**

##### **General**

14. While the choice of tracing systems will remain a national prerogative, States will ensure that they are capable of undertaking traces and responding to tracing requests in accordance with the requirements of this instrument.
15. States receiving information related to tracing illicit small arms and light weapons in accordance with the provisions of this instrument and in the context of a tracing request will respect all restrictions placed on its use. Furthermore, States will guarantee the confidentiality of such information. Restrictions on use may include, inter alia:
  - (a) The information exchanged will be released only to competent authorities designated by the requesting State and/or authorized personnel, to the extent necessary for the effective implementation of this instrument;
  - (b) The information exchanged will be used only for purposes consistent with this instrument; or

A large grid of dots for taking notes, consisting of 30 rows and 60 columns of small, light gray dots.

- (c) The information exchanged may not be released to anyone else without the prior consent of the State providing that information.

Where for legal, constitutional or administrative reasons, the confidentiality of the information cannot be guaranteed or the restrictions placed on its use in accordance with the present paragraph cannot be maintained by the requesting State, the requested State will be so informed at the time the tracing request is made.

#### **Tracing requests**

- 16. A State may initiate a tracing request in relation to small arms and light weapons found within its territorial jurisdiction that it considers to be illicit under the provisions of paragraph 6 above.
- 17. To ensure smooth and effective cooperation in tracing, requests for assistance in tracing illicit small arms or light weapons will contain sufficient information, including, inter alia:
  - (a) Information describing the illicit nature of the small arm or light weapon, including the legal justification therefor and, to the extent possible, the circumstances under which the small arm or light weapon was found;
  - (b) Markings, type, calibre and other relevant information to the extent possible;
  - (c) Intended use of the information being sought.

#### **Responses to tracing requests**

- 18. States will provide prompt, timely and reliable responses to tracing requests made by other States.
- 19. States receiving a tracing request will acknowledge receipt within a reasonable time.
- 20. In responding to a tracing request, the requested State will provide, subject to paragraph 22 below, all available information sought by the requesting State that is relevant for the purpose of tracing illicit small arms and light weapons.
- 21. The requested State may seek additional information from the requesting State where a tracing request does not contain the information required in paragraph 17 above.
- 22. States may delay or restrict the content of their response to a tracing request, or refuse to provide the information sought, where releasing the information would compromise ongoing criminal investigations or violate legislation providing for the protection of confidential information, where the requesting State cannot guarantee the confidentiality of the information, or for reasons of national security consistent with the Charter of the United Nations.
- 23. If a State delays or provides a restricted response to a tracing request, or refuses to provide the information sought, on the grounds identified in paragraph 22 above, it will inform the requesting State of the reasons for this. The requesting State may subsequently seek clarification of this explanation.

## **VI. Implementation**

### **General**

- 24. In accordance with their constitutional processes, States will put in place, where they do not exist, the laws, regulations and administrative procedures needed to ensure the effective implementation of this instrument.

A large grid of dots for taking notes, consisting of 30 rows and 50 columns of small, light gray dots.

25. States will designate one or more national points of contact to exchange information and act as a liaison on all matters relating to the implementation of this instrument.
26. States will cooperate on a bilateral and, where appropriate, on a regional and international basis to support the effective implementation of this instrument.

**International cooperation and assistance**

27. States in a position to do so will, upon request, seriously consider rendering technical, financial and other assistance, both bilaterally and multilaterally, in building national capacity in the areas of marking, record-keeping and tracing, in order to support the effective implementation of this instrument by States.
28. States in a position to do so are also encouraged to seriously consider international cooperation and assistance to examine technologies that would improve the tracing and detection of illicit small arms and light weapons, as well as measures to facilitate the transfer of such technologies.
29. States will encourage initiatives, within the framework of the United Nations Programme of Action to Prevent, Combat and Eradicate the Illicit Trade in Small Arms and Light Weapons in All Its Aspects, that mobilize the resources and expertise of, and where appropriate cooperation with, relevant regional and international organizations to promote the implementation of this instrument by States.

**United Nations**

30. States will cooperate, as appropriate, with the United Nations to support the effective implementation of this instrument.
31. States will, as soon as possible after the adoption of this instrument, provide the Secretary-General, through the Department for Disarmament Affairs of the Secretariat, with the following information, updating it when necessary:
  - (a) Name and contact information for the national point(s) of contact;
  - (b) National marking practices related to markings used to indicate country of manufacture and/or country of import as applicable.
32. States hereby request the Secretary-General to collate the information provided by States pursuant to paragraph 31 above and to issue it to States Members of the United Nations, providing the assistance requested for the implementation of the instrument by States, as well as assisting States to interact on a bilateral basis.

**International Criminal Police Organization**

33. States, where appropriate, will cooperate with the International Criminal Police Organization (Interpol) to support the effective implementation of this instrument.
34. States that are members of Interpol will promote the implementation of this instrument when participating in Interpol's organs.
35. States, where appropriate, in accordance with Interpol's statutory rules, are encouraged to make full use of Interpol's mechanisms and facilities in implementing this instrument. Interpol may, at the request of the concerned State, assist in the following areas:
  - (a) Facilitation of tracing operations conducted within the framework of this instrument;

A large grid of dots for taking notes, consisting of 30 rows and 50 columns of small, light gray dots.

- (b) Investigations to identify and trace illicit small arms and light weapons;
- (c) Wherever possible, building national capacity to initiate and respond to tracing requests.

**VII. Follow-up**

36. States will report on a biennial basis to the Secretary-General on their implementation of this instrument including, where appropriate, national experiences in tracing illicit small arms and light weapons as well as measures taken in the field of international cooperation and assistance. This report may form part of a State's national report on its implementation of the United Nations Programme of Action to Prevent, Combat and Eradicate the Illicit Trade in Small Arms and Light Weapons in All Its Aspects.
37. States will meet on a biennial basis to consider the reports mentioned in paragraph 36 above. These meetings will be held within the framework of relevant meetings convened for the United Nations Programme of Action to Prevent, Combat and Eradicate the Illicit Trade in Small Arms and Light Weapons in All Its Aspects, where such meetings are in fact convened.
38. States will review the implementation and future development of this instrument within the framework of conferences that review the United Nations Programme of Action to Prevent, Combat and Eradicate the Illicit Trade in Small Arms and Light Weapons in All Its Aspects.

\* \* \* \*

A large grid of dots for taking notes, consisting of 30 rows and 60 columns of small, light gray dots.



## Annex II: Selected countries and their procedures and regulations as regards marking and tracing of SALW

Country	Obligation to mark all SALW in production, consistent with emerging international standards	Other requirements for marking (I = all imported arms must be marked. I2= Secondary marking at import E = exported arms must be marked R = all registered civilian arms must be marked)	Measures to tackle unmarked or inadequately marked arms (C= Criminalization of possession and/or removal of marking; M= Marking; D = Destruction)	Detailed records kept on holdings, transactions and transfers of SALW	Cooperation in tracing (A = actively cooperates in tracing; B = has expressed willingness to cooperate)
Armenia	Some	I, E, R	C, D	Yes	B
Australia	Yes	I	M, D	Yes	A
Belarus	No	I	No	Yes	B
Botswana	No	I, E	M or D	No (unreliable and not computerized)	A
Canada	Yes (new legislation)	I, E	M	Yes	A
Colombia	No		No	No	A
Ecuador			D	Yes	A
Estonia	Yes	No	Yes	Yes	A
France	Yes	No	D	Yes	
Germany	Yes (some secondary marking)	I, I2, E, R		Yes	
Ghana		I	M, D	Yes	B
Indonesia	Some	I			
Kenya	No			No	
Macedonia	(Law planned for revision)	I	M, D	Yes	A

A large grid of dots for taking notes, consisting of 30 rows and 60 columns of small, light gray dots.

*Marking and Tracing of Small Arms and Light Weapons (SALW)*

Nicaragua	Only requirements are for military arms to be marked	I	M, D	Yes	A
Pakistan	Yes	R	C	Yes	
Singapore	Yes	Yes	Yes	Yes	No
Solomon Islands	No	I, R	M		A
South Africa	Yes	I	C,D	Yes	A
Sri Lanka	Yes				
Tonga		R	M		
Trinidad and Tobago		I	No	Yes	A
USA	Yes	I	M, D		A
Venezuela	No	No		Yes	A

Source: Table adapted by author from Section Global overview of international co-operation and assistance, in: REVIEWING ACTION ON SMALL ARMS 2006. Assessing the first five years of the UN programme of Action, by Biting the Bullet, pp.33-84, <http://www.iansa.org/un/review2006/redbook2006/index.htm>

A large grid of dots for taking notes, consisting of 30 rows and 50 columns of small, light gray dots.

## Annex III: Comparative analysis of the UN Firearms Protocol, UN PoA and UN M&TI

Agreement	UN Firearms Protocol	UN M&T Instrument	UN Programme of Action (PoA)
<b>Status of agreement</b>	Legal	Political	Political
<b>Participation</b>	States that have either ratified or acceded to the Protocol (63 States Parties as of July 2007; see <a href="http://www.unodc.org/unodc/crime_cicp_signatures_firearms.html">http://www.unodc.org/unodc/crime_cicp_signatures_firearms.html</a> )	The Instrument applies equally to all UN Member States.	The Instrument applies equally to all UN Member States.

A large grid of dots for taking notes, consisting of 30 rows and 60 columns of small, light gray dots.

<p><b>Relevant commitments</b></p>	<p>▪ <b>Marking and Tracing</b></p> <p>(Article 8) States Parties are required to ensure the unique marking of small arms at the time of manufacture. Markings must include:</p> <ul style="list-style-type: none"> <li>▪ Name of manufacturer;</li> <li>▪ Country or place of manufacture;</li> <li>▪ Serial number.</li> </ul> <p>States Parties are also required to ensure the marking of each imported firearm. These markings should include:</p> <ul style="list-style-type: none"> <li>▪ Identification of the country of import;</li> <li>▪ Year of import;</li> <li>▪ Unique marking if the firearm does not already have one.</li> </ul> <p>States Parties are further required to ensure appropriate marking at the time of transfer from Government stocks to the civilian market. This marking should allow identification of the transferring country.</p>
<p>All weapons should be marked at the time of manufacture. Markings should include:</p> <ul style="list-style-type: none"> <li>▪ Name of manufacturer;</li> <li>▪ Country of manufacture;</li> <li>▪ Serial number;</li> <li>▪ Year of manufacture;</li> <li>▪ Weapon type/model;</li> <li>▪ Weapon calibre.</li> </ul> <p>States are also asked to ensure appropriate marking at the time of transfer from Government stocks to the civilian market. This marking should allow identification of the transferring country.</p>	<p>(Section II, para 7-8) All weapons should be marked at the time of manufacture. Markings should include:</p> <ul style="list-style-type: none"> <li>▪ Manufacturer;</li> <li>▪ Country of manufacture;</li> <li>▪ Serial number.</li> </ul> <p>All unmarked weapons should either be marked or destroyed;</p> <p>Unmarked or inadequately marked weapons should not be transferred.</p>

A large grid of dots for taking notes, consisting of 30 rows and 50 columns of small, light gray dots.



<ul style="list-style-type: none"> <li>▪ <b>Record-keeping</b></li> </ul>	<p>(Article 7) Records on firearms and firearm transfers should include, <i>inter alia</i>:</p> <ul style="list-style-type: none"> <li>▪ Marking information;</li> <li>▪ Countries of import, export and transit;</li> <li>▪ Issuance and expiration dates of international licenses and authorizations;</li> <li>▪ Final recipient;</li> <li>▪ Description and quantity transferred firearms, parts and components and ammunition.</li> </ul> <p>States Parties should require records with the above information to be maintained for at least 10 years.</p> <p>Where possible, they should also require records to be kept on firearm parts, components and ammunition that are illicitly manufactured or trafficked.</p>	<p>Choice of record-keeping and required information is left up to the State;</p> <p>Records on weapon markings and transfers should be kept for at least 20 years;</p> <p>Manufacturing records should be kept for at least 30 years;</p> <p>Where possible, all records should be kept indefinitely.</p>	<p>(Section II, para 9) Records on the manufacture, holding and transfer of SALW should be kept for as long as possible;</p> <p>Records should be kept in such a way as to allow their prompt access by national authorities.</p>
---	--	--	---

A large grid of dots for taking notes, consisting of 30 rows and 50 columns of small, light gray dots.

<p>▪ <b>Cooperation</b></p>	<p>(Articles 12-14, 19) States Parties are required to cooperate in tracing firearms, their parts and components and ammunition, including by providing prompt responses to requests for assistance in tracing.</p>	<p>States are required to ensure they are capable of undertaking traces and responding to tracing requests;</p> <p>Requests for assistance in tracing illicit SALW should contain, <i>inter alia</i>;</p> <ul style="list-style-type: none"> <li>▪ Information on and justification of the illicit nature of the weapon and circumstances under which it was found;</li> <li>▪ Markings, weapon type, calibre, etc. on the weapon;</li> <li>▪ Intended use of the information requested.</li> </ul> <p>States should provide prompt, timely and reliable responses to tracing requests made by other States and acknowledge receipt of such a request within a reasonable time. Circumstances under which States may delay, restrict or refuse to provide the information requested are also provided in the Instrument.</p>	<p>(Section III, para 9-12) States should cooperate with one another in tracing illicit SALW through the exchange of relevant information;</p> <p>States should strengthen their ability to cooperate in tracing illicit SALW in a timely and reliable manner, and examine technologies that would facilitate this.</p>
-----------------------------	---	--	---

A large grid of dots for taking notes, consisting of 30 rows and 50 columns of small, light gray dots.

<p><b>Value added</b></p>	<p>Provides specific guidelines for marking weapons, including markings at the time of import;</p> <p>Calls for the maintenance of records on parts and components and ammunition that are illegally manufactured or trafficked with a view to preventing and detecting illegal activities in the future;</p> <p>Legally-binding.</p>	<p>Enhances the length of time that records must be kept;</p> <p>Establishes and elaborates obligations and procedures for reliable and timely cooperation in tracing illicit SALW.</p> <p>Calls on States to provide assistance in building marking and tracing capacity in other States.</p> <p>Establishes follow-up mechanisms whereby States are asked to meet and report on their implementation of the Instrument on a biennial basis, within the framework of the UN Programme of Action on SALW (UN PoA).</p>	<p>The PoA recommends the undertaking of a study to examine the feasibility of developing an international instrument on marking and tracing (Section IV, c), a process out of which the M&amp;TI was borne;</p> <p>The PoA has an established review mechanism that provides a framework for assessing progress in each of the document's commitment areas, including marking and tracing.</p>
<p><b>Limitations</b></p>	<p>Firearm records are only required to be kept for 10 years, which is significantly shorter than the lifespan of most SALW;</p> <p>Does not specify the obligations and procedures for cooperation in tracing (who, what, how?);</p> <p>Does not apply to state to state transactions;</p> <p>Does not require the marking of firearm parts, components and ammunition;</p> <p>Only focuses on firearms, and specifically those used in crime; and not on weapons illegally held or used in civil or international conflicts.</p>	<p>The Instrument only applies to weapons and not their parts, components and ammunition;</p> <p>No common minimum standard is advanced to mark weapons at import;</p> <p>As a politically-binding document, implementation of the Instrument is voluntary.</p>	<p>Ammunition and other explosives are not included within the marking and tracing commitments;</p> <p>Recommendations for marking and tracing in the PoA are not comprehensive or detailed enough;</p> <p>As a politically binding document, implementation of the PoA is voluntary.</p>

A large grid of dotted lines for taking notes.

## Annex IV: Marking and tracing procedures of SALW in Germany

**There are a number of elements in the German system on marking, record-keeping and tracing SALW that reflect best practices on the international level.** The example of Germany can therefore be used as a case study that could illustrate what options exist as regards procedures, laws and techniques for marking, record-keeping and tracing, and that could highlight strengths and weaknesses in already existing procedures.

### Marking requirements

- Provisions establishing obligations to mark *war weapons* are contained in section 12 (7) (3) of the *War Weapons Control Act* in conjunction with section 13 of the *Second Ordinance Implementing the War Weapons Control Act*. **No exceptions are allowed from the obligation to mark war weapons.**
- The marking of firearms by industry is governed by section 24 (1) through (5) of the *Weapons Act*. **Arms manufacturers and arms dealers are under an obligation to warrant that every firearm produced, to be used, sold or imported in the area of application of the Weapons Act is duly, and uniquely, marked** with a sign containing data on:
  - The type of ammunition or—if no ammunition is used—the type of projectiles.
  - A serial number.

If unmarked weapons are found, the competent authorities, as a rule, submit them to destruction, unless they constitute evidence in a criminal case under investigation or pending a final ruling, or are retained in order to be used for e.g. educational purposes of federal or state police forces. **Manufacture of unmarked or inadequately marked SALW constitutes an administrative offence pursuant to section 53 (1) (9) of the Weapons Act.**

- **In Germany, all war weapons as well as firearms and their main components that are commercially produced in, imported or otherwise transferred into Germany must be marked with a unique sign of the producer or the importer.** The mark must be readily recognizable and of a permanent nature to identify the producer or importer.
- **This mark must include a stylized eagle to denote Germany as country of manufacture or import.**
- **Markings on SALW must also include a serial number.**
- To increase the transparency in marking SALW, Germany has begun to introduce the stamp “DE” as a central identification code.

A large grid of dots for taking notes, consisting of 30 rows and 60 columns of small, light gray dots.



**Violations of the obligation to appropriately mark firearms, or to ensure that such markings exist before ceding firearms, are punishable as an administrative offence with a fine of up to 10,000 EUR.**

## Marking methods

- Marking methods vary depending on the material to be marked and requirements of end-users. One method of marking SALW increasingly used by manufacturers is that of **laser marking**. Benefits of laser markings include:
  - The advantage of laser marking is that it is **a flexible and economically efficient method to mark metals and plastics in even hard to reach places**.
  - Marking lasers and their operating software **can be easily integrated into SALW production systems**.
  - Laser marking and engraving machines can also **be used to mark weapons after their production**.

## 1. Markings on German SALW

### 1.1 German Federal Armed Forces

Each weapon of the Federal Armed Forces is unambiguously marked and bears the following information: manufacturer, weapon type, caliber, month and year of delivery *ex works*, serial number, proof firing stamp, possibly additional marks, such as maintenance information. The marks are applied in accordance with the standards of applicable technical manuals and are unique.

### 1.2 Federal Revenue Administration

In addition to the required data as described above (see 1.1 German Federal Armed Forces), weapons in use with the Federal Revenue Administration are permanently marked with the acronym "BZV."

### 1.3 Federal and State Police Forces

- **SALW held by Federal and State Police Forces are, apart from the obligatory markings on firearms, marked with abbreviations identifying the relevant forces holding the weapons.**
- Pursuant to section 6 (1) and (2) of the *Proof Firing Act*, as amended, a proof firing stamp as well as a property sign—e.g. "BMI" (signifying the Ministry of the Interior) indicating that the weapon is in use with the Federal Ministry of the Interior—are stamped or engraved on all arms used by federal authorities.

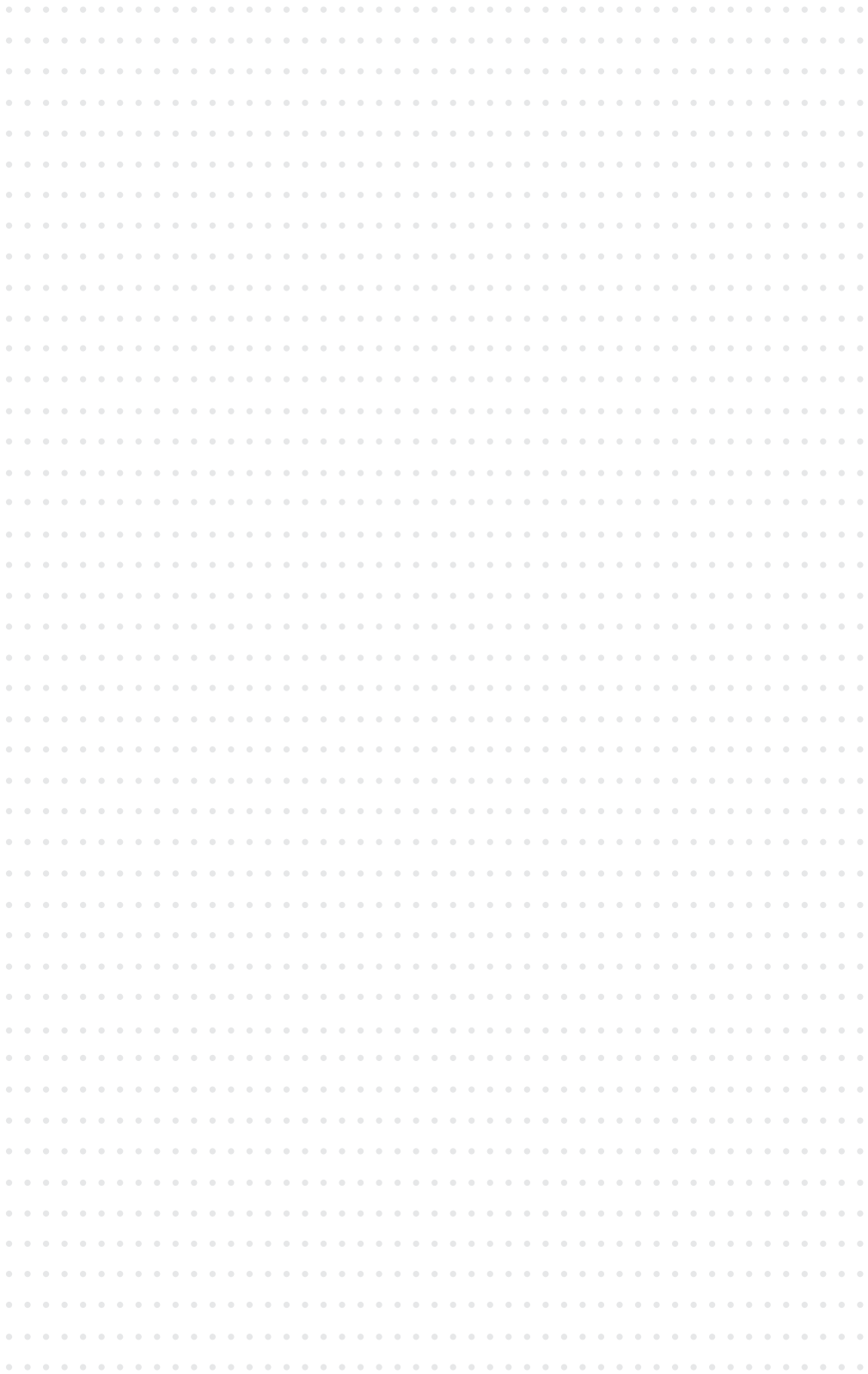

- Arms belonging to the Federal Customs Administration, the Federal Police and the state police forces must bear a mark indentifying the owning agency.
- Arms of the state police forces are marked with a state-specific sign of ownership containing an abbreviation of the respective state and/or of the name of the institution. For example, the abbreviations "HB" and "Pol.Br." designate weapons in use with the police force of the Freie Hansestadt Bremen, the smallest German federal state.

## 1.4 Civilian Possession of Firearms

- **Possession of SALW considered as war weapons for private purposes is prohibited in Germany.** The possession of firearms by civilians is regulated by the Weapons Act (*Waffengesetz*):
  - Under this act, individuals and entities who possess firearms require a license for the possession of firearms (*Waffenbesitzkarte*) which lists each individual firearm and its markings in their possession.
  - Licenses may be obtained after an application to local police authorities.
  - License holders must notify authorities about any planned acquisition of weapons and provide information on the recipient of a firearm in cases of transfers in ownership.
  - Local police then inform the authorities in the area where the recipient of the weapon is located, who has to register the received weapon with the local police.

## 2. Records on the manufacture, holding and transfer of SALW under German jurisdiction

- **All license holders are obliged to keep the necessary documents for at least ten years** in order to make on-site inspections of the supervising authorities possible. Such on-site inspections take place regularly and may be carried out as spot inspections.
- Recordkeeping in the federal back-up register of SALW maintained by the Federal Police is unlimited in time, thus warranting that police weaponry can be traced even after the life-time of the weapons.
- Additionally, **each arms manufacturer is obliged to keep an arms manufacturing register** (*Waffenherstellungsbuch*) **and a register of the trade in arms** (*Waffenhandelsbuch*). These registers contain information on:
  - The production of arms.
  - The recipients of the arms.
  - The production numbers.

A large grid of dots for taking notes, consisting of 30 rows and 60 columns of small, light gray dots.

- The production signs (e.g. registered trademarks or the name of the manufacturer).  
Upon consultation of the registers, it is possible to determine whether a specific marked arm was manufactured by the company in question.
- Markings may differ according to clients' wishes, but it is guaranteed that a later identification is possible.
- As to **non-military weapons, inspections take place once a year; they are carried out by the competent regional administrative authority.**
- Concerning **war weapons, companies have to observe special reporting obligations by submitting bi-annual statements to the Federal Office of Economics and Export Control (BAFA) on all registered transactions. Every second year the Office carries out inspections based on these statements.**

## 2.1 Record-keeping

### 2.1.1 Manufacturers and dealers

- Manufacturers and dealers are obliged to maintain 'arms books'. In cases of transfers, arms books must identify the name and address of a weapon's recipient and, for war weapons, also the date of transfer and name and address of the transport agent. Information on a ceded weapon must be kept for at least ten years after the transfer of the weapon and regulations stipulate penalties for the falsification of arms books.
- Many SALW manufacturers in Germany operate, for reasons of efficiency, electronic in-house record-keeping systems for such books. This also allows manufacturers, when provided with a serial number of a weapon bearing their mark, to immediately identify the recipient of a weapon transferred from their facilities.
- Copies of pages in war weapons books identifying, *inter alia*, the origin or recipient of SALW considered as war weapons must be submitted, on a six monthly basis, to the Federal Office of Economics and Export Control (BAFA), which carries out regular on-site inspections every second year, and may carry out challenge inspections. Books on the manufacture and transfer of other SALW must be submitted, upon request, to the police. Regional administrative authorities carry out on-site inspections once a year to verify the information contained in these books.

### 2.1.2 Federal and State Armed Agencies

- Federal armed agencies register the weapons in their possession separately:
  - The Federal Armed Forces register information on SALW under their authority in either electronic or paper-based format on a variety of organisational levels.
  - SALW held by customs are registered in a central electronic register maintained by the Federal Revenue Administration.

A large grid of dots for taking notes, consisting of 30 rows and 60 columns of small, light gray dots.

- SALW held by the Federal Border Police and by the Federal Criminal Police Office are also registered in central electronic registers maintained by these agencies.
- These registers have been adapted to the need of the specific agencies and allow for the complete tracing of the movements of a weapon from its point of acquisition by the relevant agency till its sale or transfer to another end-user, its destruction, or disappearance through loss or theft.
  - The requirements for the maintenance of central electronic registers differ according to the number of registered weapons and to the changes in possession that must be recorded.
  - One of these registers contains some 20,000 SALW and is maintained and updated by one person working in a full-time position.
  - Information in these registers is kept indefinitely which allows for the tracing of a weapon in the records even decades after a weapon had been transferred by the relevant agency.

### Legislation

- As lawmaking in the field of war weaponry is a matter of exclusive federal legislation, the federal states (*Länder*) have the right to legislate in matters concerning SALW not designed as war weapons only to the extent the Federal Republic has refrained from legislating on the federal level; Article 74 (1) (4a) of the Basic Law.
- After the entry into force, on 1 April 2003, of the most recent amendment to the Weapons Act, the federal states will practically only retain the right to legislate on state police SALW issues and on the administration of non-military SALW recordkeeping, where a parallel system applies with a federal back-up register of SALW maintained by the Federal Police and local registers on non-military SALW ownership.
- Reflecting the federal structure of Germany, police forces of Germany's federal states (*Länder*) maintain their own record-keeping systems for SALW held by them. The record-keeping systems differ from state to state and often information on weapons is registered locally. Due to pressures to enhance efficiency, State Police Forces increasingly opt for specialised software for SALW registers in local stations and work towards the centralisation of these local-level registers within their state.
  - It is up to local police forces to determine whether to opt for electronic record-keeping systems. Where electronic registers exist, they tend to be localised and do not allow for electronic transfer of data on civilian-held firearms between local police authorities.

## 3. Transfers

- In case of the retransfer of SALW that have previously been imported, the original exporting state is, as a rule, notified before the retransfer of the weapons.

A large grid of dots for taking notes, consisting of 30 rows and 60 columns of small, light gray dots.



- A standardized procedure is observed in relation to States participating in the Wassenaar Arrangement; authenticated end-user certificates are used.

## 4. Tracing

- Generally speaking, illicit SALW are traced by the Federal and State Police and the Federal Armed Forces, as a rule, initiated by a so-called tracing request forwarded by Interpol to the country of manufacture.
- In Germany, all measures to trace illegal SALW are taken by the Federal Criminal Police Bureau.
- If a tracing request is received by the Bureau due to indications that the weapon in question appears to be manufactured in Germany without carrying a federal or state authority marking, investigations do not only address the manufacturer, but even the Federal Ministry of Economics and Technology as licensing authority and the Federal Agency for Economics and Export Controls as control authority.
- If the tracing request clearly indicates that the weapon in question carries a federal or state authority marking, the military or police registers will be consulted.

SALW held and issued by State authorities can be traced by referring the marking to registers kept:

- By the Federal Armed Forces.
- The federal back-up register of SALW maintained by the Federal Police.
- The central weapons register of the Federal Revenue Administration, as the case may be.

## 5. Cooperation on Tracing

### Federal Armed Forces

- The Federal Armed Forces have established an effective system of cooperation with the Federal Criminal Police Bureau—and, if necessary, via the Bureau with Interpol—when it comes to investigating theft of SALW occurring in the Federal Armed Forces.
- During Peace Support Operations (PSO) the Federal Armed Forces are closely in cooperation with local authorities and/or international (i.e. UN) police forces in tracing illicit SALW.

### Federal and State Police Forces

- The process of tracing illicit SALW is, as a rule, initiated by a so-called tracing request forwarded by Interpol to the country of manufacture.
- In Germany, all measures to trace illegal SALW are taken by the Federal Criminal Police Bureau.
- If a tracing request is received by the Bureau due to indications that the weapon in question appears to be manufactured in Germany without carrying a federal or state authority marking, investigations do not only address the

A large grid of dots for taking notes, consisting of 30 rows and 60 columns of small, light gray dots.

manufacturer (see 2. Records on the manufacture, holding and transfer of SALW under German jurisdiction), but even the Federal Ministry of Economics and Technology as licensing authority and the Federal Office of Economics and Export Control (BAFA) as control authority.

- If the tracing request clearly indicates that the weapon in question carries a federal or state authority marking, the registers enumerated (see 3. Tracing above) will be consulted.

#### Federal Customs Administration

- The customs authorities address all requests concerning identification of sale channels of illicit SALW to the Federal Criminal Police Bureau.

## 6. Brief analysis of strengths and shortcomings of the German system for tracing SALW<sup>36</sup>

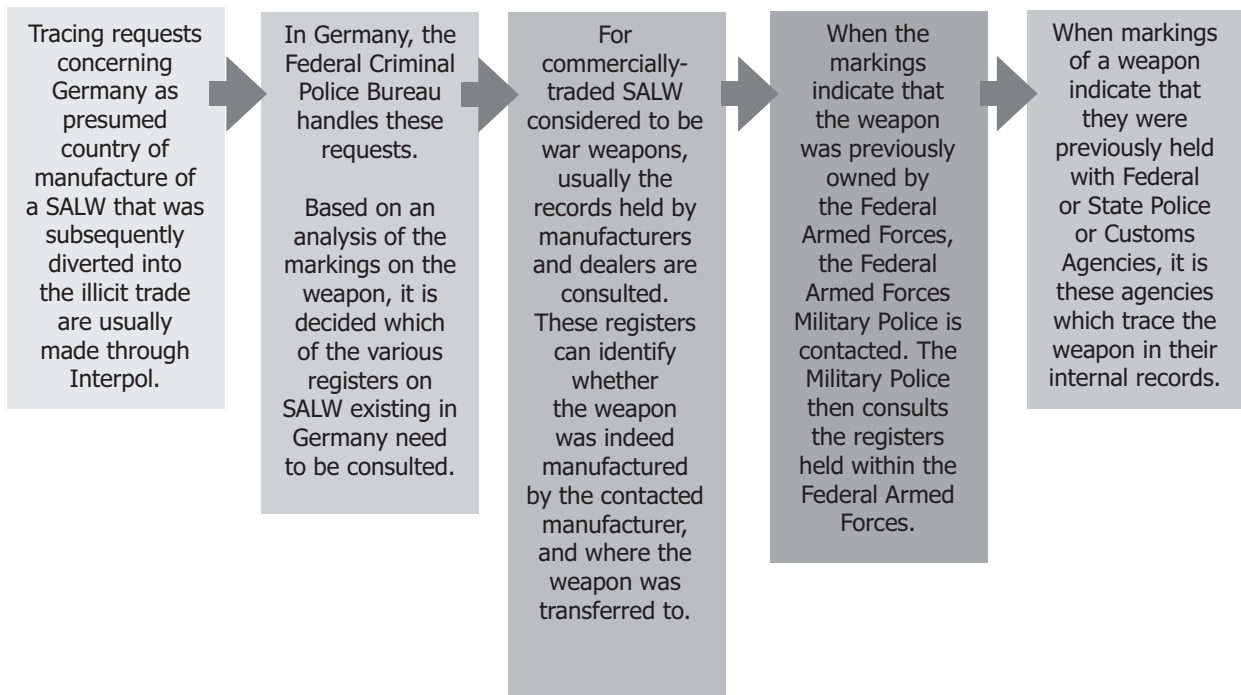

<sup>36</sup> Information for this sub-section derives from: "FEASIBILITY OF A SALW TRACING AGENCY IN GERMANY, Briefing on the SALW tracing system in the Federal Republic of Germany and scope for possible improvements", by Holger Anders

A large grid of dotted lines for taking notes, consisting of 30 rows and 40 columns of dots.

## Strengths

**There are several elements in the German system on marking, record-keeping and tracing SALW that reflect best practices on the international level.** Regarding the **marking of SALW**, best practices include:

- An obligation expressed in national law that every SALW produced or transferred into Germany must have permanent and easily recognisable markings that identify the manufacturer or importer as well as the weapon's unique identifier.
- The obligation to apply additional markings to SALW held by security forces to identify the relevant holder such as the military or federal and state police forces.
- Facilities of agencies, such as the procurement office for the Federal Customs Administration, that apply required additional post-production markings for weapons themselves.

In relation to **record-keeping systems**, best practices include:

- The obligation of manufacturers and dealers to maintain 'arms books'. In these books the serial numbers and other marks of produced or held SALW, and in cases of transfers, their recipient, are registered.
- For transfers of SALW considered as weapons of war in Germany, arms books must also identify involved transport agents. For reasons of efficiency, several SALW manufacturers keep arms books in electronic format.
- Arms books for war weapons must regularly be submitted to the Federal Office for Economics and Export Control.
- There are regular on-site inspections to verify information contained in these arms books by this office. Regular on-site inspections at facilities of manufacturers and dealers in SALW falling under the Weapons Act are carried out by regional administrative authorities.

**SALW held by civilians** must be registered with local police, and security forces are obliged to maintain complete record-keeping systems on SALW held by them. Best practice here includes:

- Centralized and electronic registers kept by the Federal Customs Administration and the Federal Border Police for the weapons held by these agencies respectively.
- These registers, similar to the electronic arms books kept by certain manufacturers, allow for the immediate identification of a weapon's path and destination while under the agency's responsibility.

## Shortcomings

- The absence of one national agency centralising information on SALW falling under Germany's jurisdiction as well as those entering or leaving its jurisdiction.

A large grid of dots for taking notes, consisting of 30 rows and 60 columns of small, light gray dots.

- Record-keeping systems for security forces are fragmented between the individual agencies and are in certain cases maintained in paper form or as electronic systems that are not interconnected.
- There is also no centralization of information on the paths of civilian-held weapons and manufacturers and dealers are not obliged to regularly submit weapons falling under the Weapons Act to authorities' arms books on SALW.
  - The path of an individual SALW while under Germany's jurisdiction and its destination must be pieced together from several sources. This takes time and may hinder the reliable tracing of an illicit weapon.
- There are no systematic inspections of cross-border SALW transfers. Customs usually can only control a small portion of the goods entering or leaving a state's jurisdiction. When transfers, including imports, are checked by customs, these controls usually limit itself to checking shipping documents. There is therefore no inspection of quantities and markings in a SALW transfer and their verification against recorded information in these documents. There are also no systematic post-delivery inspections to verify that imported weapons are still in the possession of the authorised dealers or agencies<sup>37</sup>.

## Recommendations

- The federal government should ensure that all of the agencies under its authority establish and centralize **electronic record-keeping systems on SALW** held by the individual agencies. For reasons of efficiency, it might be desirable to integrate these separate registers under the authority of one single agency. The federal government should also encourage the governments of the individual federal states to upgrade registers on SALW held by the State Police Forces.
- The introduction of **one central electronic register on civilian-held SALW**, or, at a minimum, the establishment of such registers on the level of states of the Federal Republic of Germany should equally be encouraged.
- Manufacturers and dealers of SALW should be required to **keep and regularly submit arms books on both SALW** considered to be weapons of war and those not considered as such **to relevant authorities in electronic format**. The Federal Office for Economics and Export Control should correspondingly be equipped with the technical means to receive and store submitted information electronically. The arms books on the trade in SALW not considered as weapons of war should be extended to include information on transport agents involved in a transfer.
- The **creation of one specialized national agency** could considerably contribute to streamlining the fragmented tracing mechanisms currently employed in Germany, free up resources in those agencies currently undertaking relevant control functions and lead to an overall reduction of costs for maintaining the present national tracing system. The specialized agency should be mandated to, among other tasks, centralize SALW record-keeping systems. For the purposes of tracing illicit SALW, the most efficient measure is the establishment of one electronic register that records the history of each SALW under Germany's jurisdiction. This

<sup>37</sup> FEASIBILITY OF A SALW TRACING AGENCY IN GERMANY, Briefing on the SALW tracing system in the Federal Republic of Germany and scope for possible improvements, by Holger Anders

A large grid of dots for taking notes, consisting of 30 rows and 60 columns of small, light gray dots.



would mean a register that integrates the record-keeping systems on SALW held by the security forces with those on civilian-held weapons and the arms books maintained by manufacturers and dealers. Such a register, if adequately set up, can ensure commercial confidentiality of submitted information and the protection of personal data.

Sources: National Report on the Implementation of the United Nations Programme of Action to Prevent, Combat and Eradicate the Illicit Trade in Small Arms and Light Weapons in All Its Aspects, Federal Republic of Germany, Berlin, April 15, 2007, <http://www.auswaertiges-amt.de/diplo/de/Aussenpolitik/Abroestung/Downloads/KleineLeichteWaffen-Dt-Antwort-25Apr07.pdf>. FEASIBILITY OF A SALW TRACING AGENCY IN GERMANY, Briefing on the SALW tracing system in the Federal Republic of Germany and scope for possible improvements, by Holger Anders

A large grid of dots for taking notes, consisting of 30 rows and 50 columns of small, light gray dots.

# Annex V: Marking and tracing procedures of ammunition in Germany

## 1. Record-keeping of ammunition

### 1.1 Ammunition stockpiles under the responsibility of the MoD

- Ammunition is verified during its entire lifetime so that it can be traced from leaving the factory to use or disposal. This verification features an IT-based procedure, manually-processed balance cards in the depots, and verification of use in ammunition and explosives logs.
- These procedures are audited every three years in accordance with paragraph 78 of the Federal Budget Ordinance.  
The staff of the ammunition administration is specially trained in handling ammunition.

### 1.2 Ammunition stockpiles under the responsibility of the Ministry of the Interior

- Ammunition is verified during its entire lifetime so that it can be traced from leaving the factory to use or disposal. This verification features manually-processed balance cards in the depots and verification of use in ammunition and explosives logs. Verification is also partly based on an IT-based procedure which is uniformly governed by regulations.
- Stocks are checked at least annually, and the verification procedure is audited every three years in accordance with paragraph 78 of the Federal Budget Ordinance.  
The staff of the ammunition administration is specially trained in handling ammunition.

### 1.3 Ammunition stockpiles under the responsibility of the Federal Ministry of Finance

- Ammunition is administered by the Customs Procurement Branch and the body which reports ammunition requirements, aided by their respective gunnery instructors.
- The Customs Procurement Branch collects the applications of the individual bodies, assesses their plausibility and places the order. Small reserves are again provided for where necessary.

A large grid of dots for taking notes, consisting of 30 rows and 50 columns of small, light gray dots.

- The Procurement Branch commissions the supplier to deliver the ammunition to the relevant bodies directly, and ensures that the order is processed in accordance with regulations.
- The reserves are stored in the depots of the suppliers or the Procurement Branch and distributed as special resources if necessary.
- Each body which reports requirements supervises the delivery of ammunition for its field of activity. It organizes and oversees the appropriate transfer of ammunition to its subordinate bodies:
  - The gunnery instructors administer ammunition stocks within their respective bodies by keeping records of all ammunition issued to persons carrying firearms or used for training purposes.
  - Ammunition used by the Federal Customs Administration is usually tailor-made, and carries an exclusive serial number or brand. This ensures that the ammunition is allocated only to Federal Customs Administration and certain bodies within it.

## 2. Cooperation

### 2.1 Bilateral cooperation in the field of ammunition administration and storage

- Responsibility for storing, administrating and controlling access to ammunition stockpiles lies with the state concerned, as does the responsibility for ascertaining demand and identifying and reducing any stocks in surplus. **All cooperation and support is thus aimed at enabling these states to solve matters of substance and related problems themselves. Germany's bilateral efforts are thus rooted in the principle of "helping others to help themselves."** However, there may be isolated cases—notably where the civil population or the environment is seriously endangered—where immediate and direct action is needed to prevent an escalation or to reduce damage. In such cases and upon request, Germany is prepared to consider support of this kind.
- **The level of risk may vary greatly depending on the quantity, age and type of ammunition involved, as well as on how it is stored. The extent and type of support needed is determined by this level of risk, together with the capabilities of the state concerned and, in some cases, of the third-party support provided.** The type of risks to people and the environment which arise from large-caliber ammunition are primarily the result of shortcomings in ammunition safety. The same applies to other explosive materials, whereby the risks of unauthorized access, inappropriate use and illicit trade also come into play. The dangers posed by small-caliber ammunition with regard to safety and operation and the related risk of damage to the environment are more limited; the greatest dangers arise from unauthorized access and uncontrolled proliferation. **Every German action thus begins with a comprehensive and basic assessment of the level of risk in the location in question. The primary aim is then to build on the individual efforts of the state concerned.**

A large grid of dots for taking notes, consisting of 30 rows and 50 columns of small, light gray dots.

## 2.2 Multilateral efforts in the field of ammunition administration and storage

- Multilateral efforts with regard to the administration and security of public ammunition stockpiles seek to create international framework conditions enabling and promoting effective action to improve ammunition administration and storage and to reduce ammunition stockpiles.

**The ultimate aim is to counter the related danger of illegal transfer.**

### 2.2.1 Forms of multilateral action

- OSCE participating states have taken up the issue of stockpiling conventional ammunition with a view to significantly improving the current situation by means of a set of measures and through international cooperation. **Germany's efforts within the OSCE apply particularly to the drawing up of best practice guidelines.** These should give all participating states access to the knowledge and experience already gathered in the OSCE area with regard to certain issues of stockpiling conventional ammunition, helping them to overcome their ammunition problems. Germany took a leading role in drawing up two sets of guidelines for the topics "transporting conventional ammunitions by land" and "**marking, record-keeping and traceability of conventional ammunition**". **The guidelines** are not intended to and cannot replace the legal provisions on ammunition already in force in many OSCE participating states. However, they **can help decision-makers to review and, where necessary, refine existing national provisions, or to introduce such provisions for the first time.**

Source: Problems arising from the accumulation of conventional ammunition stockpiles in surplus, German Reply to the request for a statement by the Secretary-General of the United Nations, Berlin, 2 April 2007

A large grid of dots for taking notes, consisting of 30 rows and 60 columns of small, light gray dots.



## Annex VI: Tracing process of a recovered weapon

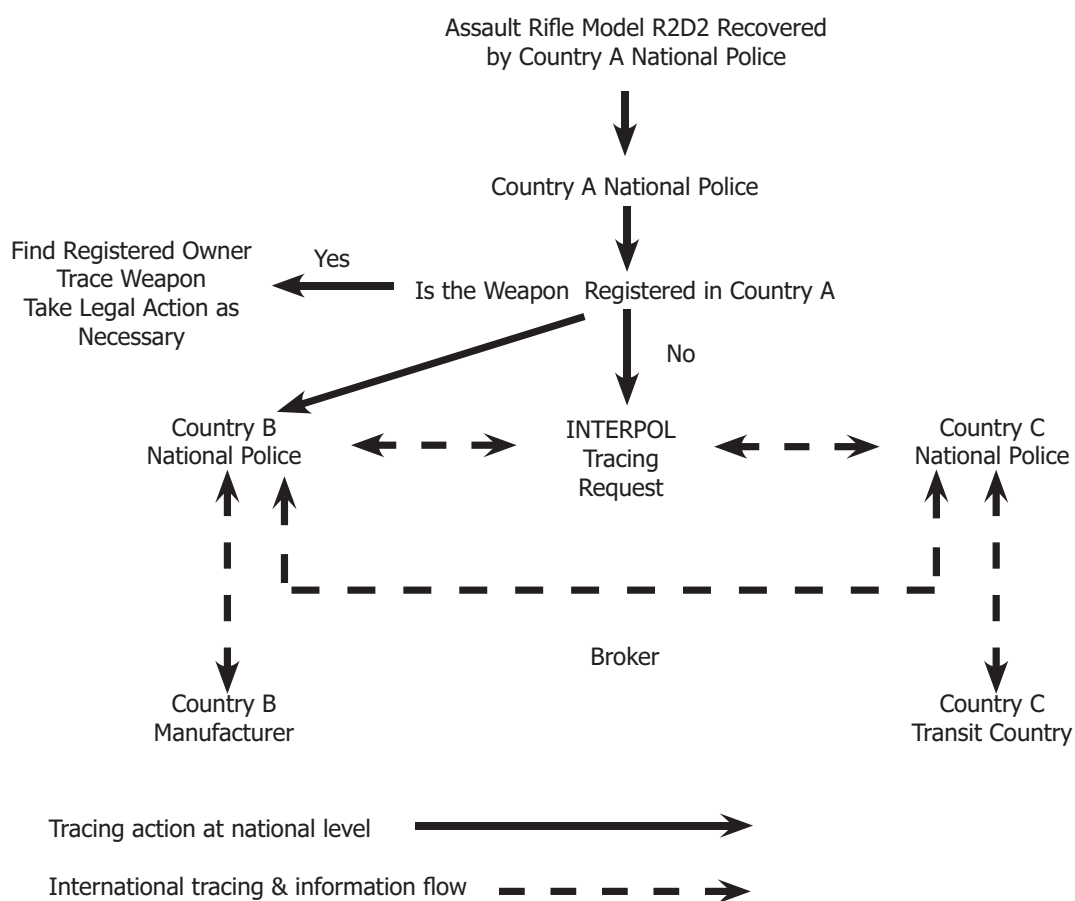

A large grid of dots for taking notes, consisting of 30 rows and 60 columns of small, light gray dots.



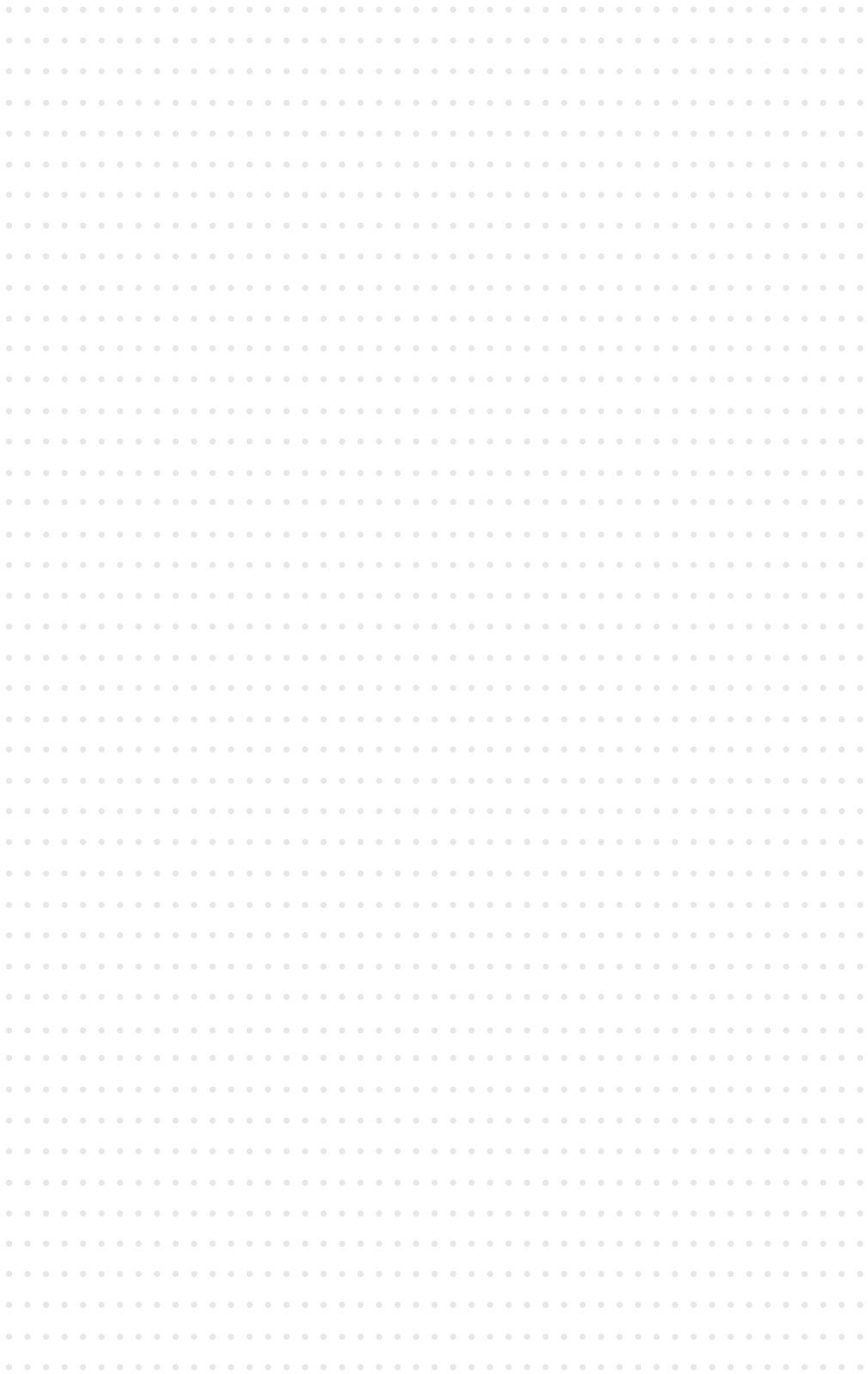

## References

- Anders, Holger. 2004. "Feasibility of a SALW Tracing Agency in Germany." Briefing on the SALW tracing system in the Federal Republic of Germany and scope for possible improvements. Groupe de recherche et d'information sur la paix et la sécurité (GRIP). 16 June. <http://www.grip.org/bdg/g4544.htm>
- \_\_\_\_\_. 2006. "Following the Lethal Trail: Identifying Sources of Illicit Ammunition" In Pézard, Stéphanie and Holger Anders (eds.) *Targeting Ammunition. A Primer*. A Small Arms Survey publication in cooperation with partners.
- Batchelor, Peter and Glenn McDonald. 2006. "Too close for comfort: an analysis of the UN tracing negotiations." *Disarmament Forum* No. 1, <http://www.unidir.ch/pdf/articles/pdf-art2429.pdf>
- Carle, Christopher. 2006. "Small arms ammunition: light at the end of the barrel?" *Disarmament Forum*. Taking Action on Small Arms, No. 1, UNIDIR. <http://www.unidir.ch/pdf/articles/pdf-art2430.pdf>.
- Control Arms Campaign. 2004. *Tracking Lethal Tools. Marking and Tracing Arms and Ammunition: a central piece of the arms control puzzle*. Amnesty International, Oxfam and IANSA. [http://www.oxfam.org.uk/what\\_we\\_do/issues/conflict\\_disasters/downloads/tracking\\_lethal\\_tools.pdf](http://www.oxfam.org.uk/what_we_do/issues/conflict_disasters/downloads/tracking_lethal_tools.pdf)
- Federal Government of Germany. 2005. „National Report on the Implementation of the United Nations Programme of Action to Prevent, Combat and Eradicate the Illicit Trade in Small Arms and Light Weapons in All Its Aspects.“ 30 April, Berlin: Federal Republic of Germany.
- \_\_\_\_\_. 2007. „Problems arising from the accumulation of conventional ammunition stockpiles in surplus.“ German Reply to the request for a statement by the Secretary-General of the United Nations, Berlin, 2 April.
- Greene, Owen, Sally Holt and Adrian Wilkinson. 2005. "Ammunition stocks: promoting safe and secure storage and disposal." *Biting the Bullet briefing* No. 18, London: Biting the Bullet. <http://www.seesac.org/reports/BTB18.pdf>.
- IANSA. See: International Action Network on Small Arms.
- International Action Network on Small Arms. 2004. „Tracing Illicit Small Arms.“ Opportunities for the first substantive session of the Open-Ended Working Group on Tracing Illicit Small Arms and Light Weapons, IANSA, Draft – May. [http://www.iansa.org/issues/documents/iansa\\_position\\_paper\\_on\\_tracing.doc](http://www.iansa.org/issues/documents/iansa_position_paper_on_tracing.doc)
- \_\_\_\_\_. 2006. *Reviewing Action on Small Arms. Assessing the first five years of the UN Programme of Action*. Biting the Bullet. <http://www.iansa.org/un/review2006/redbook2006/index.htm>
- \_\_\_\_\_. No year. „Essential elements for an international convention on tracing of small arms and light weapons.“ [http://www.iansa.org/issues/documents/essential\\_elements\\_for\\_a\\_convention\\_on\\_tracing.doc](http://www.iansa.org/issues/documents/essential_elements_for_a_convention_on_tracing.doc)

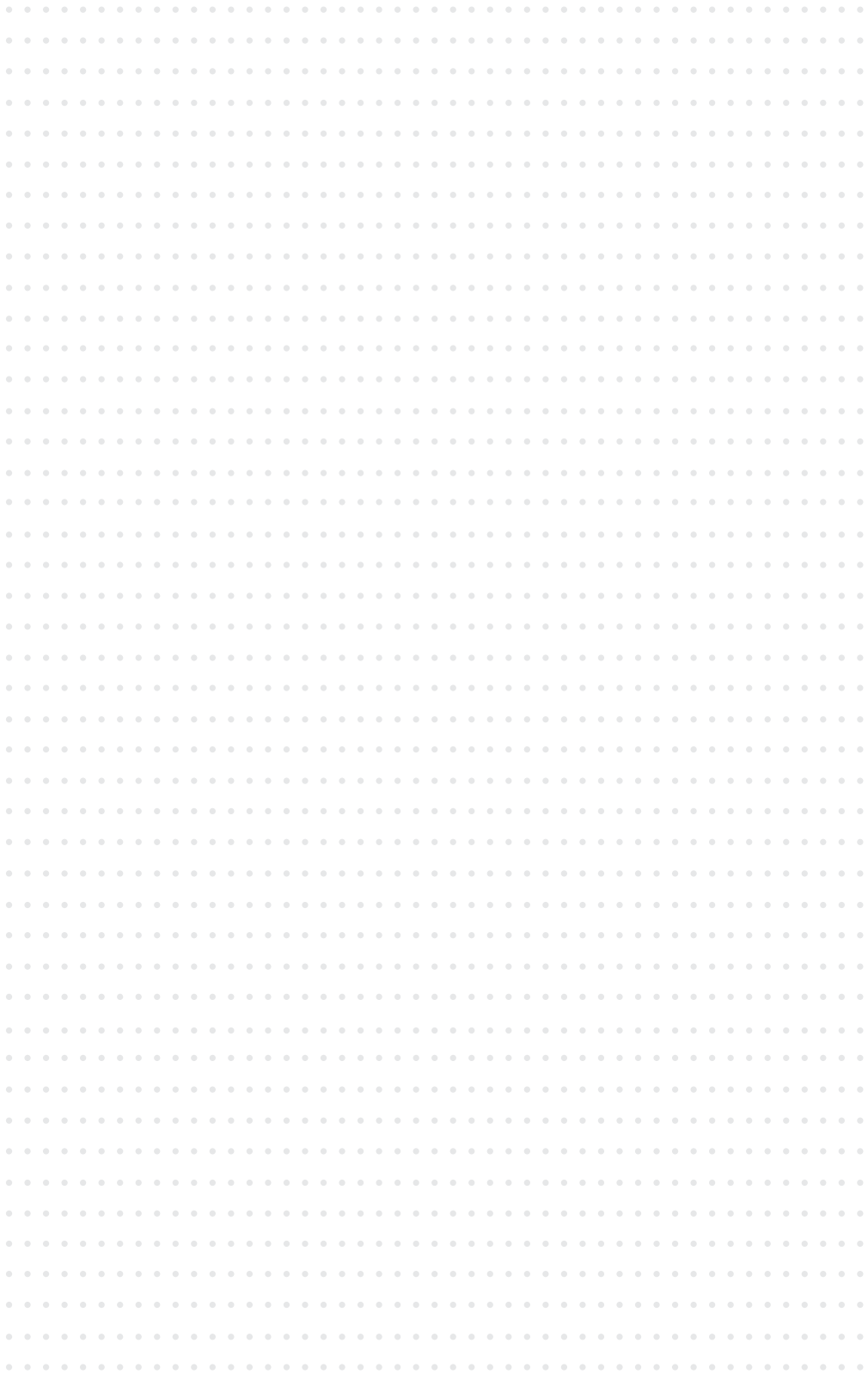

- McDonald, Glenn. 2006. "The International Tracing Instrument: Challenges and Opportunities." PrepCom side event at the 2006 Small Arms Review Conference. Small Arms Survey: UN New York, 13 January
- \_\_\_\_\_. 2006. "Connecting the Dots. The International Tracing Document." *Small Arms Survey Yearbook*.
- Office of the Special Representative of Interpol to the United Nations. 2006. „Interpol's position regarding the Implementation of the International Instrument to Enable States to Identify and Trace, in a Timely and Reliable Manner, Illicit Small Arms and Light Weapons." 29 June. <http://www.un.org/events/smallarms2006/pdf/Interpol.pdf>
- Organization for Security and Co-operation in Europe. 2000. „Best Practice Guide on National Controls over Manufacture of Small Arms and Light Weapons." 24 November.
- \_\_\_\_\_. 2003. „Best Practice Guide on Marking, Record-keeping and Traceability of Small Arms and Light Weapons." *Handbook of Best Practices on Small Arms and Light Weapons*. 19 September. [http://www.osce.org/publications/fsc/2003/12/13550\\_31\\_en.pdf](http://www.osce.org/publications/fsc/2003/12/13550_31_en.pdf)
- OSCE. See: Organization for Security and Co-operation in Europe.
- Oxfam International. 2006. "Ammunition: the fuel of Conflict." *Oxfam Briefing Note*, 15 June. [http://www.oxfam.org/en/files/bn060615\\_ammunition/download](http://www.oxfam.org/en/files/bn060615_ammunition/download)
- United Nations. 2001. "Protocol against the Illicit Manufacturing of and Trafficking in Firearms, Their Parts and Components and Ammunition, supplementing the United Nations Convention against Transnational Organized Crime." UN Document A/RES/55/255. [http://www.unodc.org/pdf/crime/a\\_res\\_55/255e.pdf](http://www.unodc.org/pdf/crime/a_res_55/255e.pdf)
- \_\_\_\_\_. 2005. "International Instrument to Enable States to Identify and Trace, in a Timely and Reliable Manner, Illicit Small Arms and Light Weapons." UN Document A/CONF.192/15. [http://www.un.org/events/smallarms2006/pdf/international\\_instrument.pdf](http://www.un.org/events/smallarms2006/pdf/international_instrument.pdf)
- \_\_\_\_\_. 2001. „Programme of Action to Prevent, Combat and Eradicate the Illicit Trade in Small Arms and Light Weapons in All Its Aspects." UN Document A/CONF.192/15. <http://disarmament.un.org/cab/poa.html>
- UNGA. See: United Nations General Assembly.
- United Nations General Assembly. 2005. "International Instrument to Enable States to Identify and Trace, in a Timely and Reliable Manner, Illicit Small Arms and Light Weapons." UN Document A/CONF.192/15 of 8 December. <http://disarmament.un.org/cab/docs/International%20instrument%20English.pdf>.
- \_\_\_\_\_. 2005. "Report of the Open-ended Working Group to Negotiate an International Instrument to Enable States to Identify and Trace, in a Timely and Reliable Manner, Illicit Small Arms." UN Document A/60/88 of 27 December. <http://disarmament.un.org:8080/cab/oewg/Report.pdf>.





